

Template for submitting comments/inputs on Draft Test Guide titled “Solar Photo Voltaic (SPV) Based Standalone/Hybrid Power Supply for Wi-Fi Terminals & Other Similar Telecom Terminals (TEC 66101:2026).

Name of Manufacturer/Stakeholder:

Organization:

Contact details:

Clause No.	Clause Description	Comments, if any	Remarks, if any

Note: The comments/inputs on the draft Test Guide (Draft Test Guide No. TEC 66101:2026) may be furnished in the above format through email to adgfa-tec-dot@gov.in with copy to dirfa.tec@gov.in and ddgfla.tec@gov.in at the earliest and within prescribed time period.



परीक्षण निर्देशिका

टीईसी ६६१०१:२०२६

TEST GUIDE

TEC 66101:2026

for

वाई-फाई टर्मिनलों एवं अन्य समान दूरसंचार टर्मिनलों हेतु सौर फोटोवोल्टाइक आधारित स्वतंत्र हाइब्रिड वद्युत आपूर्ति प्रणाली

SOLAR PHOTO VOLTAIC (SPV) BASED STANDALONE/ HYBRID
POWER SUPPLY FOR Wi Fi TERMINALS & OTHER SIMILAR
TELECOM TERMINALS
(STANDARD No.: TEC 66100:2026)



ISO 9001:2015

दूरसंचार अभियांत्रिकी केंद्र
खुशीदलाल भवन, जनपथ, नई दिल्ली-110001, भारत

DRAFT

© टीईसी, २०२६

© TEC, 2026

इस सर्वाधिकार सुरक्षित प्रकाशन का कोई भी हिस्सा, दूरसंचार अभ्यांत्रिकी केंद्र, नई दिल्ली की लखत स्वीकृति के बिना, किसी भी रूप में या किसी भी प्रकार से जैसे - इलेक्ट्रॉनिक, मैकेनिकल, फोटोकॉपी, रिकॉर्डिंग, स्कैनिंग आदि रूप में प्रेषित, संग्रहीत या पुनरुत्पादित न किया जाए।

All rights reserved and no part of this publication may be reproduced, stored in a retrieval system or transmitted, in any form and by any means - electronic, mechanical, photocopying, recording, scanning or otherwise, without written permission from the Telecommunication Engineering Centre, New Delhi.

FOREWORD

Telecommunication Engineering Centre (TEC) is the technical arm of Department of Telecommunications (DOT), Government of India. Its activities include:

- Framing of TEC Standards for Generic Requirements for a Product/Equipment, Standards for Interface Requirements for a Product/Equipment, Standards for Service Requirements & Standard document of TEC for Telecom Products and Services
- Formulation of Essential Requirements (ERs) under Mandatory Testing and Certification of Telecom Equipment (MTCTE)
- Field evaluation of Telecom Products and Systems
- Designation of Conformity Assessment Bodies (CABs)/Testing facilities
- Testing & Certification of Telecom products
- Adoption of Standards
- Support to DoT on technical/technology issues

For the purpose of testing, four Regional Telecom Engineering Centers (RTECs) have been established which are located at New Delhi, Bangalore, Mumbai, and Kolkata.

ABSTRACT

This document enumerates detailed test schedule and procedure for evaluating conformance / functionality / requirements / performance of standalone and Hybrid power supply using Solar Photo Voltaic (SPV) as

per GR No. TEC 66100:2026.

DRAFT

CONTENTS

<i>Section</i>	<i>Item</i>	<i>Page No.</i>
A	History Sheet	5
B	Introduction	6
C	General Information/General Instruction	7
D	Testing Team	8
E	List Of Test Equipment's	8
F	Equipment Configuration Offered	9
G	Equipment /System Manuals	9
H	Clause-Wise Test Type And Test No.	10
I	Test Setup & Procedures	73
J	Summary Of Test Results	103

A. HISTORY SHEET

<i>S. No.</i>	<i>Standard/ Document No</i>	<i>Title</i>	<i>Remarks</i>
1.	TEC 66101:2026	Solar Photo Voltaic based standalone/ Hybrid Power Supply for Wi Fi Terminals & Other Similar Telecom Terminals	First issue

DRAFT

B. INTRODUCTION

This document enumerates detailed test schedule and procedure for evaluating conformance / functionality / requirements / performance of standalone and Hybrid power supply using Solar Photo Voltaic (SPV) as per GR No. TEC 66100:2026.

DRAFT

C. General information_

Sl. No.	General Information	Details <i>(to be filled by testing team)</i>	
1.	Name and Address of Applicant		
2.	Date Of registration:		
3.	Name and No. of GR/IR/Applicant's Spec. against which type approval sought		
4.	Details of Equipment		
	Type of Equipment	Model No.	Serial No.
I.			
II.			
5.	Any other relevant Information:-		

:

D. Testing team: (to be filled by testing team)

S. No.	Name	Designation	Organization	Signature
1.				
2.				
3.				

E. List of the test instruments:

S. No.	Name of test Instrument	Quantity	Make / Model <i>(to be filled by testing team)</i>	Validity of calibration <i>(to be filled by testing team)</i> dd/mm/yyyy	Remark
1.					
2.					
3.					
4.					

F. Equipment Configuration Offered: (to be filled by testing team)

(a) <Equipment/product name> Configuration:

Sl. No.	Item	Details	Remarks

Relevant information like No. of cards, ports, slots, interfaces, size etc. may be filled as applicable for the product

(b) <Other equipment name> Configuration:

Sl. No.	Item	Details	Remarks

Relevant information like No. of cards, ports, slots, interfaces, size etc. may be filled as applicable for the product

G. Equipment System Manuals: (to be filled by testing team)

Availability of Maintenance manuals, Installation manual, Repair manual & User Manual etc. (Y/N)

H. Clause-wise Test Type and Test No.:

<i>Clause No.</i>	<i>Clause</i>	<i>Type of Test / Test No. etc.</i>
1.0	INTRODUCTION	
1.1	This document contains the generic requirements of standalone and Hybrid power supply using Solar Photo Voltaic (SPV) for powering ONTs, Wireless terminals(WTs), Fixed Wireless terminals(FWTs), low power BTSs and similar Telecommunication equipment deployed to provide two- way communication in rural areas.	Information
1.2	These power supplies are capable of catering to load requirements of 60W, 5A continuous or up to 120 AH per day for 12V telecom equipments, 240W, 10A continuous or up to 240 AH per day for 24V telecom equipments and up to, 480W, 10A continuous or up to 240 AH per day for 48V telecom equipments.	Information
1.3	<p>SPV Power supply specified in this document may be of two types:</p> <p>a) Standalone SPV Power Supply: Standalone SPV power supply has only provision for SPV Power generating source. This type of power supply has a larger battery bank to provide the higher autonomy. SPV Array in this case is also bigger than hybrid power supply (described below) because all the load requirements are to be met by SPV power source only. Rating and the voltage of the power supply will depend on the operating voltage and power requirement of the telecom equipment to be fed. A Block-schematic showing different component of the power supply is given in annexure - 1.</p> <p>b) Hybrid SPV Power Supply: Hybrid SPV Power Supply</p>	Information

	<p>works on both SPV power source and Switch Mode Power supply (SMPS). This type of power supply is so designed that 50% to 100% of the load requirement is met by SPV and the remaining by the SMPS, the SMPS may be required for occasional topping up of the batteries in case of unfavourable weather conditions. The hybrid power supply may as well be configured and used in Grid only mode in space constrained environments (no suitable space available for solar panels) where grid is available for more than 8 Hours a day. The percentage of load to be met by SPV power source is required to decide the size of the SPV array. Rating and the voltage of the power supply will depend on the operating voltage and power requirement of the telecom equipment to be fed. Hybrid SPV power supply shall be of two types (i) Non- integrated SMPS Hybrid SPV power supply, (ii) Integrated SMPS hybrid SPV power supply, as explained in clause 1.5.</p>	
1.3.1	<p>This hybrid type of power supply shall have provision, so that, when both the output of SMPS and SPV power source are available, they shall take the load collectively. SPV power source shall deliver the load as per its available power and rest of the load shall be taken care of by SMPS. For proper load sharing of the two power sources, it shall be ensured that voltage of the SPV power source, even in worst working conditions (high SPV cell temperature) is higher than that of the SMPS.</p>	Information
1.4	<p>The SPV Power Source is a non-conventional energy source, comprised of a SPV Modules, which convert Solar Energy (Sun light) directly into DC electricity to charge the battery, through a charge controller. The Charge Controller is used to control the charging process.</p>	Information
1.5	<p>SMPS is comprised of FR-FC (Float Rectifiers - cum - Float Chargers), which converts AC in regulated DC and its</p>	Information

	<p>control circuitry. Output of the SMPS is used to cater to the load and simultaneously charge the battery. Hybrid SPV power supply shall be of two types:</p> <p>1. Non-integrated SMPS Hybrid SPV power supply: SMPS shall be designed as standalone system and gets integrated to SPV Charge controller through the switch. A Block-schematic showing different component of this power supply is given in annexure -2a.</p> <p>2. Integrated SMPS Hybrid SPV power supply: SMPS shall be fully integrated within the Hybrid power supply that accepts AC mains power and SPV power as inputs. A Block-schematic showing different component of this power supply is given in annexure -2b.</p>	
2.0	DESCRIPTION	
2.1	Power Supply Configuration: The major components of the SPV Power Supply are as follows:	Information
2.1.1	Solar Photo-voltaic Generating Source: SPV generating source is constituted of the following building blocks:	Physical Check
2.1.1.1	SPV Module: SPV Module is the basic building block of the SPV power supply, which consists of a number of Solar Cells (a Semi Conductor Device which when exposed to sun light produces DC electricity) connected in series or in series - parallel configuration and hermetically sealed with a toughened and highly transparent front glass cover. These modules are connected in series and parallel to get the desired power and voltage. Two rating of these modules, as per this document, have been specified as 12V/50Wp to 12V/300Wp and 24V/250Wp to 24V/550Wp and above. However, purchaser may specify power '300Wp or higher' as per the requirement.	Physical Check

2.1.1.2	<p>SPV Panel: SPV Modules of same rating are connected in series to form a SPV panel to get the desired voltage. For example for a 12V equipment, the module itself becomes a panel, while for 48V equipment, four 12V SPV modules are connected in series to form a 48V SPV panel and two 24V modules are to be connected in series to form a 48V SPV panel.</p> <p>If required by purchaser, for a 48V equipment, less than four or four or more than four(in case of MPPT based CCU)12V SPV modules may be connected in series to form a 48V SPV panel and less than two or two or more than two(in case of MPPT based CCU) 24V modules (for standalone application only) may be connected in series to form a 48V SPV panel. However, higher voltage thus generated shall not be hazardous and all possible protection arrangement shall be made from safety point of view. (as per IEC 60950-1{2005}).</p> <p>If desired by Purchaser/User, the advantages of PWM control techniques may be taken.</p>	Physical Check
2.1.1.3	<p>SPV Array: A number of panels are connected in parallel or series to get the desired power. This whole combination is called an array. The SPV array is so designed that, it provided the necessary battery charging current and simultaneously meets the load demand, when sufficient sunshine is available.</p>	Physical Check
2.1.2	<p>Charge Controller Unit (CCU): Charge controller unit should have common MPPT Charge Controller module for both standalone SPV power supply and non-integrated SMPS Hybrid SPV power supply.</p>	Undertaking from OEM
2.1.2.1	<p>It shall provide for the necessary DC power supply to the load and battery and also protect battery bank from over charge, deep discharge, reverse polarity and short circuit, thereby ensuring that the electrical characteristics are met for optimum</p>	Undertaking from OEM, Test Case-1 & Test case-21

performance and reliability. It monitors all the functions of SPV power source and SMPS through common DSCA (some on charge controller along with SMPS and all other on the SMPS). CCU shall also monitor all the functionalities of integrated SMPS based hybrid SPV system, while in case of non-integrated SMPS based hybrid SPV system, SMPS module shall have its own monitoring functions. It provides for termination for output of the SPV array, output of the SMPS (through a switch), load and battery. It shall house all the necessary alarms, monitoring and control circuits. It shall also provide for the mounting of the lightning and surge protection devices (SPV side on the charge controller itself or some external box/unit, while SMPS side lightning and surge protective devices on the SMPS or some external box/unit.) The system should have Stage – I & II SPD as per TEC GR No. TEC 66130:2025. In case of small 12 V SPV power supplies using mono-blocks up to 50AH, the battery may be accommodated inside the charge controller.

The CCU shall compose the following features:

(i) Accommodating the charge controller and battery in same enclosure may reduce life and performance of charge controller. There should be adequate arrangement such that the rise in the temperature of one unit should not impact the temperature of the other. However purchaser may specify the requirement to have charge controller and battery to be kept in same enclosure or separate enclosures.

(ii) SMPS output shall not be terminated at the input of charge controller unit. It shall be connected in parallel with charge controller output internally or externally. There shall be provision to switch off SMPS output. This can be done using a

	<p>control signal from Charge controller which controls SMPS or a switch. There shall be provision of load sharing as per clause 1.3b whenever Solar Power is available.</p> <p>(iii) Charge controller shall be capable of working in extreme temperatures of -15°C to +55°C ambient without any de-rating in its power handling capabilities as Indian locations have extreme temperatures and any temperature related de-rating of power or performance will not be effect system performance.</p> <p>(iv) The Solar Charge Controller shall be based on MPPT technology which can charges battery from Solar panels arrays of higher or lower voltage. It should utilize the maximum possible energy from the solar panels so that more energy can be harvested from same Solar panels. However, higher voltage thus generated shall not be hazardous and all possible protection arrangement as per IEC 60950-1(2005) shall be made from safety point of view.</p> <p>(v) The Solar Charge Controller more than 60 V shall have the galvanic isolation and telecom equipment should never be allowed to get exposed to the un-isolated source of power.</p> <p>Note: Charge controller should not allow any reverse current flow from the SPV power source into the FC, the CCU should prioritise SPV power over FC, and FC over battery power.</p>	
2.1.3	<p>Float Charger (FC): In hybrid Power supply, float charger(FC) can be modular or integrated depending upon non-integrated or integrate type SMPS based hybrid power supply and FC shall provide DC power supply to the load and battery when the AC commercial main are available.</p>	Information

2.1.4	<p>Battery Bank: It stores the energy generated by SPV Generating source or SMPS. The Battery capacity will depend on the load and autonomy.</p> <p>If required by the purchaser, Battery cabinet may have physical security system in place. Security system may be battery operated/AC powered for:</p> <ul style="list-style-type: none"> (i) Need based access control ensuring authorized personnel to have access when required. (ii) Thermal management that ensures controlled fans and can be connected to a fire suppression system. (iii) Complete data and audit trail to understand all operations about the site and door status. (iv) Online/offline communication. 	Undertaking
2.1.4.1	<p>12V SPV Power Supply: For 12V SPV power supply either a six cell battery of 2V cells or 12V mono-block is used. Mono-blocks of rating up to 12V/150AH are permissible for this purpose. For higher battery capacity only 2V cells shall be used.</p>	Undertaking
2.1.4.2	<p>24V SPV Power Supply: For 24V SPV power supply, a 12 cell battery formed by 2V cells is used. 12 V Mono-blocks of rating up to 150AH are permissible for this purpose. For higher battery capacity only 2V cells shall be used.</p>	Undertaking
2.1.4.3	<p>48V SPV Power Supply: For 48V SPV power supply, a 24 cell battery formed by 2V cells is used. Mono-blocks of rating up to 12V/150AH are permissible for this purpose. For higher battery capacity only 2V cells shall be used..</p>	Undertaking
2.1.5	<p>The Module Mounting Structure: SPV Modules /panels/arrays are mounted on a specially designed galvanized iron support structure .It shall also provide for angle of tilt with horizontal in accordance with the latitude of the place of installation.</p>	Physical Check
2.1.6	<p>Interconnecting Cables : Interconnecting cables are used for providing interconnection between:</p>	Undertaking

	<ul style="list-style-type: none"> — SPV modules, panels — SPV Generating Source (array) and Charge Controller — Charge controller and SMPS (Hybrid power supplies) (If required) — Charge controller and battery — Charge controller and load. <p>The Length of the interconnecting cables shall be as per the requirement of the site. The gauge of the cable shall be so chosen that the total voltage drop across the whole length of cable shall be less than 340mV (2% of voltage at peak power) for 12V SPV power generating source , 680 mV for 24 V SPV power generating source and 1.36V for 48V SPV power generating source. It shall also be capable of taking load without overheating. The termination of the cables shall be through lugs of suitable gauge. Further, the rating of the cables to be used may be decided in accordance with the guidelines given in the “Planning and Maintenance Guidelines for SPV supply No. . TEC 66079:2015 issued by TEC. The cables used shall be fire retardant and weather proof.</p>	
2.2	Power Supply Classification: These Power Supplies are classified as:	Information
2.2.1	<p>Standalone SPV Power Supply: These are further classified as:</p> <p>A. 12V Standalone SPV Power supply: Depending on the Charge Controller unit capacity and load requirements, the 12V SPV power supplies are further classified as follows:</p> <p>i) 12V/100W Standalone SPV Power supply: Composed of 12V/100W SPV power Generating source, with 12V/100W Charge controller.</p> <p>ii) 12V/200W Standalone SPV Power supply: Composed of 12V/200W SPV power Generating source, with 12V/200W Charge controller.</p>	Physical Check

	<p>iii) 12V/400W Standalone SPV Power Supply: Composed of 12V/400W SPV Power Generating source, with 12V/400W Charge controller.</p> <p>B 24V SPV Power Supply: Depending on the Charge Controller unit capacity and load requirements the 24V SPV power supplies are classified as follows:</p> <p>i) 24V/500W Standalone SPV Power Supply: Composed of 24V/500W SPV Power generating source, with 24V/500W Charge controller.</p> <p>ii) 24V/1KW Standalone SPV Power Supply: Composed of 24V/1000W SPV Power generating source, with 24V/1000W Charge controller.</p> <p>iii) 24V/2KW Standalone SPV Power Supply: Composed of 24V/2KW SPV Power Generating Source, with 24V/2KW Charge controller.</p> <p>C. 48V SPV Power Supply: Depending on the Charge Controller unit capacity and load requirements the 48V SPV power supplies are classified as follows:</p> <p>i) 48V/100W Standalone SPV Power Supply: It shall be composed of 48V/100W SPV Power Generating source with 48V/100W Charge controller.</p> <p>ii) 48V/200W Standalone SPV Power Supply: It shall be composed of 48V/200W SPV Power Generating Source with 48V/200W Charge controller.</p> <p>iii) 48V/500W Standalone SPV Power Supply: Composed of 48V/500W SPV Power generating source, with 48V/500W Charge controller.</p> <p>iv) 48V/1KW Standalone SPV Power Supply: Composed of 48V/1KW SPV Power generating source, with</p>	
--	---	--

	<p>48V/1KW Charge controller</p> <p>v) 48V/2KW Standalone SPV Power Supply: Composed of 48V/2KW SPV Power generating source, with 48V/2KW Charge controller</p> <p>vi) 48V/4KW Standalone SPV Power Supply: Composed of 48V/4KW SPV Power Generating Source, with 48V/4KW Charge controller.</p>	
2.2.2	<p>Hybrid SPV Power Supply: “Purchaser may specify overall redundancy for the power supply including the Charge controller & SMPS”. These are further classified as:</p> <p>A. 12V Hybrid SPV Power supply: Depending on the Charge Controller unit capacity and load requirements the 12V Hybrid SPV power supply is classified as</p> <p>a) 12V/100W Hybrid SPV Power Supply: It shall be composed of:</p> <p>(i) 12V/100W SPV Power Generating source with 12V/100W Charge controller.</p> <p>(ii) SMPS (based on 12V/ 6.25A FR/FC modules) with ultimate capacity of 12.5A (two FR/FC modules 12V/ 6.25A (1 for load and one for redundancy)).</p> <p>b) 12V/200W Hybrid SPV Power Supply: It shall be composed of:</p> <p>(i) 12V/200W SPV Power Generating Source with 12V/200W Charge controller</p> <p>(ii) SMPS (based on 12V/ 6.25A FR/FC modules) with ultimate capacity of 12.5A (two FR/FC modules 12V/ 6.25A (one for load and one for redundancy)).</p> <p>c) 12V/400W Hybrid SPV Power Supply: It shall be</p>	Physical Check

	<p>composed of:</p> <p>(i) 12V/400W SPV Power Generating Source with 12V/400W Charge controller</p> <p>(ii) SMPS (based on 12V/ 6.25A FR/FC modules) with ultimate capacity of 18.75A (three FR/FC modules 12V/ 6.25A (two for load and one for redundancy))</p> <p>Or</p> <p>SMPS (based on 12V/ 12.5A FR/FC modules) with ultimate capacity of 25A (two FR/FC modules 12V/ 12.5A (one for load and one for redundancy))</p> <p>Note: Purchaser may decide for procurement of 12V Hybrid SPV Power Supply based on their requirement.</p> <p>B. 48V Hybrid SPV Power Supply: Depending on the Charge Controller unit capacity and load requirements the 48V Hybrid SPV power supply is classified as:</p> <p>a) 48V/100W Hybrid SPV Power Supply: It shall be composed of:</p> <p>(i) 48V/100W SPV Power Generating source with 48V/100W Charge controller.</p> <p>(ii) SMPS (based on 48V/ 6.25A FR/FC modules) with ultimate capacity of 12.5A (two FR/FC modules 48V/ 6.25A (1 for load and one for redundancy)).</p> <p>b) 48V/200W Hybrid SPV Power Supply: It shall be composed of:</p> <p>(i) 48V/200W SPV Power Generating Source with 48V/200W Charge controller</p> <p>(ii) SMPS (based on 48V/ 6.25A FR/FC modules) with</p>	
--	---	--

	<p>ultimate capacity of 12.5A (two FR/FC modules 48V/ 6.25A (one for load and one for redundancy))</p> <p>a) 48V/500W Hybrid SPV Power Supply:</p> <p>(i) 48V/500W SPV Power Generating Source with 48V/500W Charge controller.</p> <p>(ii) SMPS (based on 48V/6.25A FR/FC modules) with ultimate capacity of 12.5A (Two FR/FC modules 48V/6.25A (1 for load and one redundancy)).</p> <p>b) 48V/1KW Hybrid SPV Power Supply:</p> <p>(i) 48V/1KW SPV Power Generating Source with 48V/1KW Charge controller.</p> <p>(ii) SMPS (based on 48V/ 6.25A FR/FC modules) with ultimate capacity of 12.5A (two FR/FC modules 48V/ 6.25A (one for load and one redundancy)).</p> <p>c) 48V/2KW Hybrid SPV Power Supply:</p> <p>(i) 48V/2KW SPV Power Generating Source with 48V/2KW Charge controller.</p> <p>(ii) SMPS (based on 48V/6.25A FR/FC modules) with ultimate capacity of 18.75A (three FR/FC modules 48V/6.25A (two for load and one redundancy)).</p> <p>OR</p> <p>SMPS (based on 48V/ 12.5A FR/FC modules) with ultimate capacity of 25A (two FR/FC modules 48V/ 12.5A (one for load and one for redundancy)).</p>	
--	---	--

	<p>d) 48V/4KW Hybrid SPV Power Supply: It shall be composed of:</p> <p>i) 48V/4KW SPV Power Generating Source with 48V4KW Charge controller.</p> <p>ii) SMPS (based on 48V/ 6.25A FR/FC modules) with ultimate capacity of 31.25A (Five FR/FC modules 48V/ 6.25A (four for load and one for redundancy)).</p> <p>Or</p> <p>SMPS (based on 48V/ 12.5A FR/FC modules) with ultimate capacity of 37.5A (three FR/FC modules 48V/ 12.5A (two for load and one for redundancy))</p>	
2.2.3	<p>Charge controller module (MPPT module) for both Standalone and Hybrid SPV power supplies is common, hence a stand alone power supply can be converted into hybrid power supply and vice-versa functionally by adding or removing the SMPS. Connections scheme/block diagram to convert Standalone SPV system into hybrid system is given at Annexure (2a).</p>	Physical Check
2.3	<p>Power Supply Sizing: The capacity of the SPV power generating source, SMPS and battery will depend upon the actual load (Off-hook current and Continuous current) of the telecom equipment and additional loads, if any. Equipment load may differ from manufacturer to manufacturer and its traffic in Erlangs. The other loads include fans lighting, soldering and inverter etc. For the calculation of the equipment load, the duty cycle has been assumed as follows:</p> <p>Daily Duty Cycle: Off Hook Current ContinuousCurrent Traffic in Erlangs</p> <p>Depending upon the power consumption by the telecom</p>	Declaration, Certificate from accredited test laboratories shall be submitted

	<p>equipment during the talk time and idle time, the actual load per day may be worked out. The other loads may be arrived at from the consumption data of each utility. The total load requirement is the additions of all the loads to be fed by the SPV power supply. On the basis of the actual load and other factors such as availability of AC mains, autonomy etc., one of the configurations as given in clause 2.2 above may be selected. It shall be clearly highlighted at the time of ordering. (Refer Ordering information at chapter 2 of this document). In case of hybrid power supply, in addition to SPV power generating system, the SMPS rating shall also be worked out. The voltage and capacity of the battery will depend on load voltage, the optimum load and `autonomy`. The size of SPV array, Charge controller, SMPS, battery, interconnecting cables may be calculated in accordance with "Planning and maintenance guidelines for SPV power supply No. TEC 66079:2015(Old No TEC/GL/TX/SPV-05/02.MAR.2015)". Rating of each components, viz., SPV Power source, SMPS, charge controller etc. may be clearly stated in the Ordering information.</p> <p>The power supply shall be designed to work within specified limits under any of the environmental conditions and shall occupy minimum space for mounting the required SPV array.</p>	
3.0	<p>FUNCTIONAL REQUIREMENTS:</p> <p>The SPV Power Generating System comprises mainly of a SPV Module - a non conventional source of power - that converts Solar Energy (Sun light) directly into DC Electricity which in turn charges battery bank through a Solar charge controller. The solar charge controller, in this case of Hybrid Power Supply shall have an in-built FC (float charger) that shall provide a regulated DC Power Supply to the load and</p>	Test Case-1

	<p>the battery bank when the AC commercial mains are available.</p> <p>Hybrid power supply for the above fixed wireless terminals shall be one single combined unit that shall be capable of working on both AC commercial mains as well as SPV power generating system. Whenever the Solar supply is available, the priority selection shall be SPV first and AC second. The system should so function always, that it should charge the battery and deliver power to the load through charge controller/Rectifier and on condition by using either Solar or AC. AC Power should come into picture from standby mode to parallel working mode.</p>	
3.1	<p>SPV Power Source (Modules, Panels/Arrays): The SPV power source shall be able to charge a 12V battery for 12V SPV power supply, 24V Battery for 24V power supply (for standalone application only) and 48 volt battery for 48V power supply through the necessary protection arrangement against the discharge of the battery through SPV panels/array during sunless period, while simultaneously feeding load.</p>	Test Case-1
3.1.1	<p>The SPV generating module & panel, during the sunny period, shall through the SPV panels -feed load as well as simultaneously charge battery (through the necessary protection arrangement against the discharge of the battery by reverse flow). The cells shall be fully encapsulated and mounted behind a toughened low iron high transmission glass surface of thickness not less than 3mm to protect the cells from moisture, dust and external environment. The contacts should be corrosion resistant. Crane/scrim glass shall be used inside the SPV module in order to help the evacuation process. Standard practice of using crane/scrim glass (not up to the edges) shall be adopted. The leads must be weather protected.</p>	Physical Check

3.1.1.1	SPV modules shall be constructed of materials and component, which are known to be resistant to damage or deleterious change when exposed outdoors for a period of 15 years in any of the climatic conditions prevailing in India and provide mechanical and environmental protection to the encapsulated components.	Undertaking to be taken from OEM, Test report
3.1.1.2	The modules shall have proven laminate construction. The laminates shall be sealed in a frame of light-weight anodised aluminium, with a suitable edge gasket/silicon rubber sealant to provide shock resistance and a further moisture barrier. The back surface shall be of impermeable aluminium foil/polyester and white refractive plastic material such as TEDLAR. The back surface can be Glass, Transparent and white refractive backsheet.	Certificates from accredited test labs are to be submitted
3.1.1.3	The sealing of edges of glass on the frames shall be hermetically tight so that rain water and dew do not enter into the cell compartment.	Certificates from accredited test labs are to be submitted.
3.1.1.4	A terminal box shall be attached to the SPV module frame. The terminal box should be resistant to moisture ingress and shall include integral by-pass diode to protect cell overheating due to localised shading.	Physical Check
3.1.1.5	The design of the solar module shall be multi-cell and modular in construction to provide the required output.	Physical Check
3.1.1.6	The solar photo-voltaic cell module is for use in terrestrial application and is to comprise of mono-crystalline/poly-crystalline PERC, TOPCon, HJT, or other advanced silicon-based technologies, connected in appropriate series or series-parallel configuration to achieve the desired output. Each module shall be fully encapsulated using advanced materials (such as multi-layer polymer backsheet or glass-glass construction).	Undertaking , Certificates from accredited test laboratories shall be submitted

3.1.1.7	The SPV modules, being used for Telecom supply, need to be characterised at NPL (National Physical Laboratory) or any BIS/ NABL /TEC recognised Test Lab.	Certificates from accredited test laboratories shall be submitted
3.1.1.8	The module must deliver full current at a load voltage corresponding to the terminal voltage of range 13.5V to 13.8 V plus the diode drop & cable drop at the maximum expected cell temperature (55 deg. C).	Undertaking to be taken from OEM,
3.1.1.9	Suitable arrangement should be made to reduce the possibility of Bird menace, no sitting places for birds should be available above the solar panel area.	Undertaking to be taken from OEM,
3.1.1.10	The module shall have positive tolerance of power.	Undertaking to be taken from OEM,
3.1.2	Panel/ Array configuration: The panel shall be modular in configuration, consisting of one module for 12V SPV power source and 4 modules connected in series for 48V SPV power source. The rating of the 12V SPV power generating modules shall be 12V/50Wp to 12V/300Wp or any other rating. The module may be selected as per the load requirements and availability of space. In case of 24V (for Standalone Application only), the rating of the 24V SPV power generating modules shall be 24V/250Wp to 24V/550Wp”(refer clause 2.1.1).	Information
3.1.2.1	The array shall be made by connecting the number of panels in parallel or series or in series -parallel combination as per requirement. The number of panels in the array shall be as per the present load requirement with the provision of adding more panels for the projected ultimate limit, whenever required at later date.	Information
3.1.3	Minimum stipulated life: The de-rating factor of 0.5%per year of the SPV Generating source /module rated power is	Undertaking to be taken from

	permissible. The module/SPV Generating source shall deliver at least 90% of its rated power in the 10th year. The de-rating factor of 0.5%/year of the SPV Generating Source/module rated power is permissible (can be high for first year). The module/SPV power generating source shall deliver at least 90% of its rated power in 10th year.	OEM
3.1.4	SPV Module Ratings: Rated power (minimum) at maximum Power Output to be specified by the manufacturer.	Undertaking to be taken from OEM
3.1.5	Peak (Maximum) Power Output: The SPV Module shall deliver minimum specified rated power at maximum power point of “IV Curve” at standard condition of 100 mw/cm ² solar intensity at 25 deg C AM(air mass coefficient) 1.5.	Test Result/ Certificates from accredited test labs are to be submitted
3.1.6	Cells: Cells can be either mono-crystalline/Polycrystalline/PERC/TOPcon or any other latest technology encapsulated Silicon Cells. All the cells used in a module shall be identical, of regular shape and shall have the same rating with tolerance +/-5%. The actual rating of the modules in a panel shall be within 5% of the average rating of the four modules. While in an array, the rating of the panels shall also be within 5% of the average rating of the panels in the SPV power generating source.	Physical Check & Manufacturer Report
3.1.7	Configuration of the module to be specified by manufacturer: Number of cells in series or in series – parallel configuration.	Information
3.1.8	Open circuit Voltage : Maximum, minimum and nominal Voltages to be specified by the manufacturer at 25 deg C. but in no case it shall be less than the reference value.	Information, Manufacturer report
3.1.9	Short circuit Current : To be specified by the manufacturer.	Declaration
3.1.10	SPV modules Voltages at peak Power point: 17.0 V (min.) for 12V Modules and 34V (min.) for 24V Module. In addition to it, SPV Vmpp should be 0.45V(min.) per cell minimum.	Undertaking to be taken from OEM

3.1.11	Voltage de-rating: shall Not more than -0.5% per deg C above 25 deg C cell temperature.	Undertaking to be taken from OEM
3.1.12	Conversion efficiency & fill factor: For Panels rating below 250 Wp: Conversion efficiency of the encapsulated cell at peak power shall not be less than 13% and that of module at peak power shall not be less than 12%. The fill factor shall be better than 68%. For Panels rating above 250 Wp: Conversion efficiency of the encapsulated cell, peak power, shall not be less than 20 % and that of module shall not be less than 19%. Fill factor shall be better than 75%.	Test Result/ Certificates from accredited test labs are to be submitted
3.2	Charge Controller Unit : The charge controller unit shall be a Hybrid power supply of single combined unit that shall be capable of working on both AC commercial mains as well as SPV power generating system.	Information
3.2.1	Voltage to Load & battery: The SPV voltage at the output of the charge controller shall be limited to 13.8V for 12V power supply, 27.6V for 24V power supply With DSCA in communication, the output of the charge controller or MPPT module shall be dynamically adjusted to ensure optimal utilization of the available Solar energy source. In case of without communication with DSCA, the output of the charge controller shall be limited to 13.8V for 12V power supply, 27.6V for 24V power supply and 55.2V for 48V power supply. The SMPS output voltage shall also be controlled within these limits. When working with SMPS, for proper load sharing of SPV power generating source and SMPS, provision shall be made in the charge controller so that it dynamically adjusts to extract the maximum possible power from the SPV array based on the available input voltage and current, ensuring optimal energy utilization and even in worst working conditions (high SPV cell temperature) the voltage of SPV source is higher than that of the SMPS.	Test Case-2

3.2.2	<p>Efficiency (SPV Section): (i) For 12V & 24V Power Supply: Efficiency of the charge controller at full load and rated output voltage of 13.5V for 12V power supply, 27V for 24V power supply and 54V for 48V power supply shall be in excess of 90%. However, purchaser may specify efficiency to be 85% for 12V system depending upon the cost effectiveness of the power supply.</p> <p>(ii) For 48V Power Supply: Efficiency of the charge controller: Under nominal input and output conditions, the power conversion efficiency shall be $\geq 93\%$</p> <p>(iii) Solar Module (MPPT) tracking efficiency shall be $\geq 98\%$ for 12V/24V/48V power supply.</p> <p>Note: For validation of this parameter, test reports of NABL accredited / TEC designated lab shall be allowed.</p>	Test Case-3 Or Test Result/Certificate s from accredited test labs are to be submitted.
3.2.3	<p>Psophometric Noise (e. m. f. weighted at 800 Hz): While working on SPV Power as well as SMPS, Psophometric Noise with a battery of appropriate capacity floated and Radio Telephone equipment connected across the output shall be within 2mVrms and ripple voltage shall be 2mVrms +/- 0.5% for float applications as per latest standards.as per ITU-T Rec. O-41.</p>	Test Case-3
3.3	<p>SMPS (Switch Mode Power Supply):</p>	
3.3.1.1	<p>Hybrid SPV power supply, in addition to SPV power source as given in the previous clauses, shall include a SMPS as detailed below:</p>	Information
3.3.1.2	<p>SMPS shall be composed of a number of FR-FC (float rectifier-cum float charger) modules to cater the load requirements. This unit shall be capable to meet the load and battery requirements when the AC mains are available. The SMPS shall be in compliance of all the requirements of this clause and its sub-clauses.</p>	

3.3.1.3	These float chargers may be either 12V or 48V as per the telecom equipment requirements.	Physical Check
3.3.1.4	Normally the load of the telecom equipments to be fed by this type of power supply is small, hence SMPS envisaged for this application are single phase of maximum current rating of 150A, based on single phase FR-FC modules of rating 6.25A, 12.5A, 25A.	Physical Check
3.3.1.5	In non-integrated SMPS based hybrid SPV system, the FR/FC modules may be mounted preferably on the top of the rack/unit for efficient extraction of heat from the modules. DSCA of the SMPS may be mounted in the upper/lower part of the rack or on side of the FR/FC modules, while FR-FC modules shall be mounted in the remaining rack. While in case of integrated SMPS based hybrid SPV system, it will employ modular configuration. The matching of the SPV Power source output and SMPS output shall be ensured by the charge controller.	Information
3.3.1.6	It shall provide for the surge protection devices for SMPS, in compliance of clause 5.6 of this GR.	Information
3.3.1.7	SMPS shall be based on Switch Mode Power Supply (SMPS) Techniques using switching frequencies of 20KHz and above. The SMPS shall be capable of, independently, meeting the load requirements of load (telecom equipment) and battery bank. SMPS is intended to be used in Float-cum- Charge mode as a regulated D.C. Power Source. The system should be expandable at rack level itself or by additional racks using the basic FR/FC modules of the same rating in non-integrated SMPS based hybrid SPV system. The prescribed FR/FC ratings are 12.5A ,and 25A. In case of integrated SMPS based hybrid SPV system, it will employ modular configuration. They all use single phase supply except for 50A basic module, which may be with single phase supply.”The	Information

	<p>Power Plant as per this GR shall be compatible with VRLA battery as well as Li-ion battery. However, at any point of time VRLA & Li-ion battery cannot work simultaneously with the SMPS power plant.</p>	
<p>3.3.1.8</p>	<p>The system shall only be based on menu driven Micro Processor Controlled Techniques (both DSCA as well as FR/FC module) for control, monitoring and alarms. DSCA shall display its Software version for both DSCA and FR/FC. Setting of all the parameters shall be through menu-driven microprocessor control only. DSCA shall have menu for selection of type of battery between VRLA and Li-ion battery and type of battery should be displayed on DSCA.</p> <p>The failure of Microprocessor or DSCA shall not affect the setting of individual FR/FC. No parameter of FR/FC modules shall be disturbed on the failure of DSCA. In this condition all the FR/FC modules shall take care of the load on default settings and share the load collectively. Only the setting of new parameters from DSCA shall be affected. In case of failure of microprocessor of FR/FC module, its last setting shall not be affected. The system shall be RS 485/RS 232 and Ethernet (SNMP Protocol) compatible, if remote monitoring is required. It shall be feasible to set any monitoring control parameter from a remote site through RS 485/ RS232 and Ethernet (SNMP Protocol). All the information regarding Control and monitoring of Power Plant data shall be accessible on demand from the remote site. The exchange of information and protocol format shall comply as per Annexure - 3 of this GR. RS 485/ RS 232 and Ethernet communication cable of suitable length (to be decided by purchaser) shall be protected with pluggable and DIN Rail Mountable surge protection devices (to be decided by purchaser) to be</p>	<p>Test Case-1 FR/FC module rating, Controller information</p> <p>Test Case-10 For failure of Microprocessor or DSCA</p> <p>Test Case-11 for RS 485 / RS 232 and Ethernet communication</p>

	<p>mounted on both side of the cable. SPD shall have surge discharge current capacity of 10KA (8/20 μsec) and lightning discharge current capacity of equal or more than 0.5 KA per line (10/350 μsec). The SPDs shall have an end of life indication either via signal disruption or a visual indication.</p>	
3.3.1.9	<p>The system shall be sufficiently flexible to serve any load from 6.25A onwards depending on manufacturer's design, rating, number of FR/FC modules, used in a rack and system configuration. To cater for higher load requirements, same type of FR/FCs mounted in the same rack or different racks, shall be capable of working in parallel load sharing arrangement in non-integrated SMPS based hybrid SPV system.</p>	Information & Physical Check
3.3.1.10	<p>In the non-integrated SMPS based hybrid power supply, The DSCA shall be provided for the ultimate capacity of the Power Plant. The DSCA, in addition to control, monitoring and alarms, shall provide for the following:</p> <ol style="list-style-type: none"> a) Termination for the batteries*. b) Termination for the exchange load. c) Interconnecting arrangement for power equipment. d) Battery Switching arrangement (Connection to/isolation from power supply)** e) Termination for AC input to the rack shall be finger touch proof, flame retardant, insulated. Use of bus-bars for the purpose is precluded. f) Termination for AC and DC to FR/FC modules. g) Circuit Breakers/fuses /MCB etc. for DC output (refer Note 3) <p>* The capacity and number of batteries shall be as per order. For the purpose of Type Approval, it shall be taken as one battery for 12V stand alone power supply and two batteries for</p>	Physical Check & Certificates from Accredited test Laboratories are to be submitted

	<p>other power supply.</p> <p>** Only CACT/NABL/TEC Designated labs approved DC contractors or `MCBs` (which do not produce spark while cutting in or out), shall be used for manualisolation /reconnection of the battery by tripping the contactor through an external switch is not permitted. circuit from any source, including switching equipment such as contactor, MCB coil and their control and sensing circuitry.</p> <p>Note-1: For AC input supply AC contactor with AC Coil shall preferably be used. AC Contactor with DC coil (if used) shall have its own power supply and shall not be fed form Exchange battery.</p> <p>Note-2: Solid state switching device may preferably be used. Relays, if used, shall be UL or CE compliant.</p> <p>Note-3: DC MCBs complying with IEC 60947-2 and having CACT approval to be used for DC output. The Fuse that shall be used, shall be DC Rated (up to 80V DC)</p>	
3.3.1.11	There shall be provision to start the SMPS without battery supply.	Physical Check
3.3.1.12	The SMPS (including FR/FCs and DSCA), shall be suitable for operation from A.C mains or a DG set (of capacity 1.25 times AC load of power plant).	Information
3.3.2	<p>Rack/Unit Configuration: The unit/Rack (in non-integrated SMPS based hybrid power system) is composed of following units, accommodated in 19" (482.6 mm) or smaller sub-rack:</p> <p>a) Float Rectifier-cum-Float Charger (FR/FC)</p> <p>b) Distribution, Switching, Control, Alarm and Monitoring (DSCA) unit.</p>	Physical Check
3.3.3	Unit Configuration:	

3.3.3.1	The unit shall employ a modular configuration to provide flexibility, keeping in view the future load requirements of D.C. Power.	Information
3.3.3.2	In non-integrated SMPS based hybrid SPV system, the FR/FC modules shall be accommodated in a rack. DSCA, for the ultimate capacity, shall be provided in first rack. AC and DC distribution may however, be provided in First/separate rack or in the individual racks. In case, distribution arrangement is provided in First/separate rack, it shall be for the ultimate unit capacity. In case the distribution is provided in the individual racks DC distribution/switching shall be for the ultimate unit capacity, while AC distribution shall be for fully equipped rack. All factory wiring for the rack shall be for the ultimate capacity so that only plugging- in of FR/FC module shall enhance the DC power output.	Physical Check

DRAFT

3.3.3.3	<p>The SMPS shall be tested for the following ultimate capacities for awarding TAC:</p> <table border="1" data-bbox="304 383 1174 1285"> <thead> <tr> <th data-bbox="304 383 464 524">Category No.</th> <th data-bbox="464 383 839 524">Basic Module</th> <th data-bbox="839 383 1174 524">Ultimate capacity</th> </tr> </thead> <tbody> <tr> <td data-bbox="304 524 464 591">1</td> <td data-bbox="464 524 839 591">12V/6.25A(Single phase)</td> <td data-bbox="839 524 1174 591">6.25A/12.5A/18.75A</td> </tr> <tr> <td data-bbox="304 591 464 658">2</td> <td data-bbox="464 591 839 658">12V/ 12.5ASingle phase)</td> <td data-bbox="839 591 1174 658">12.5A/25A</td> </tr> <tr> <td data-bbox="304 658 464 786">3</td> <td data-bbox="464 658 839 786">24V/ 6.25A(Single phase)</td> <td data-bbox="839 658 1174 786">6.25A/12.5A/18.75A/3 1.25A</td> </tr> <tr> <td data-bbox="304 786 464 913">4</td> <td data-bbox="464 786 839 913">24V/12.5A (Single phase)</td> <td data-bbox="839 786 1174 913">12.5A/25A/37.5A</td> </tr> <tr> <td data-bbox="304 913 464 981">5</td> <td data-bbox="464 913 839 981">24V/25A (Single phase)</td> <td data-bbox="839 913 1174 981">25A/50A</td> </tr> <tr> <td data-bbox="304 981 464 1108">6</td> <td data-bbox="464 981 839 1108">48V/6.25A (single phase)</td> <td data-bbox="839 981 1174 1108">6.25A/12.5A/18.75A/3 1.25A</td> </tr> <tr> <td data-bbox="304 1108 464 1227">7</td> <td data-bbox="464 1108 839 1227">48V/12.5A(Single Phase)</td> <td data-bbox="839 1108 1174 1227">12.5/25A/37.5A</td> </tr> <tr> <td data-bbox="304 1227 464 1285">8</td> <td data-bbox="464 1227 839 1285">48V/25A(Single phase)</td> <td data-bbox="839 1227 1174 1285">25A/50A</td> </tr> </tbody> </table>	Category No.	Basic Module	Ultimate capacity	1	12V/6.25A(Single phase)	6.25A/12.5A/18.75A	2	12V/ 12.5ASingle phase)	12.5A/25A	3	24V/ 6.25A(Single phase)	6.25A/12.5A/18.75A/3 1.25A	4	24V/12.5A (Single phase)	12.5A/25A/37.5A	5	24V/25A (Single phase)	25A/50A	6	48V/6.25A (single phase)	6.25A/12.5A/18.75A/3 1.25A	7	48V/12.5A(Single Phase)	12.5/25A/37.5A	8	48V/25A(Single phase)	25A/50A	Information
Category No.	Basic Module	Ultimate capacity																											
1	12V/6.25A(Single phase)	6.25A/12.5A/18.75A																											
2	12V/ 12.5ASingle phase)	12.5A/25A																											
3	24V/ 6.25A(Single phase)	6.25A/12.5A/18.75A/3 1.25A																											
4	24V/12.5A (Single phase)	12.5A/25A/37.5A																											
5	24V/25A (Single phase)	25A/50A																											
6	48V/6.25A (single phase)	6.25A/12.5A/18.75A/3 1.25A																											
7	48V/12.5A(Single Phase)	12.5/25A/37.5A																											
8	48V/25A(Single phase)	25A/50A																											
3.3.4	Electrical Requirements:																												
3.3.4.1	<p>AC input Supply: The power plant shall work from the single phase single phase FR/FC modules shall operate from single phase AC input supply. The input voltage range shall be Single Phase nominal 230 volts AC with voltage variation of - 15% to +10% at 50 Hz \pm 2 Hz. However keeping in view of specific requirement for rural area, purchaser may specify the requirement as special case as: The Power Plant shall operate from single phase AC mains supply 230 V with variation from 170 to 260 V and frequency as 50 Hz +/-2Hz.</p>	Test Case-12																											
3.3.4.2	<p>DC output Characteristics : The Module shall be capable of operating in “Auto Float-cum- Charge” mode. It shall be programmed to operate as a float rectifier or a charger,</p>	Information																											

	depending on the condition of the battery sets being sensed by the DSCA.	
3.3.4.3	Auto Float Mode:	
3.3.4.3.1	For 12 V FR/FC: The float voltage of each rectifier module shall be continuously adjustable and pre-settable at any value in the range of -12 to -14V from FR/FC, modules or DSCA.. The prescribed float voltage setting is -13.5 V for VRLA battery .	Test Case-13
3.3.4.3.2	For 48V FR/FC: The float voltage of each rectifier module shall be continuously adjustable and pre-settable) at any value in the range of -48 to -56V from FR/FC, modules or DSCA.. The prescribed float voltage setting is -54V for VRLA battery. There shall also be a provision of setting the float/charge voltages globally from DSCA . There shall also be a provision so that DSCA may over ride the values set by individual module. . Float Voltage adjustment may be made globally, and not for individual rectifiers.	Test Case-13
3.3.4.4	Auto Charge Mode:	
3.3.4.4.1	For 12V FR/FC: In Auto charge mode FR/FC shall supply battery & equipment current till terminal voltage reaches set value, which is normally -14.2V, this value shall be settable between -12V and -14.6V) and shall change over to constant voltage mode. It shall remain in this mode till a change over to float mode signal is received. (This Clause is applicable for VRLA Battery only”) For Li-ion battery setting of Float & Charge voltage should be specified by the purchaser based on the requirement.	Test Case-13
3.3.4.4.2	For 48V FR/FC: In Auto charge mode FR/FC shall supply battery & equipment current till terminal voltage reaches set value, which is normally 2.3V/cell (-55.2V, this value shall be	Test Case-13

	settable between -48V and -56V) and shall change over to constant voltage mode. It shall remain in this mode till a change over to float mode signal is received. (This Clause is applicable for VRLA Battery only).															
3.3.4.5	The DC output voltage shall be maintained within +/-1% of the half load preset voltage in the range 25% load to full load when measured at the output terminals over the full specified input range.	Test Case-14														
3.3.5	<p>Efficiency : The efficiency of the unit shall be given below:</p> <p>12V units:</p> <table border="1"> <thead> <tr> <th>Condition</th> <th>Single Phase AC</th> </tr> </thead> <tbody> <tr> <td>Under all specified Input, output conditions and load between 50 to 100%.</td> <td>better than 85%</td> </tr> </tbody> </table> <p>24V units:</p> <table border="1"> <thead> <tr> <th>Condition</th> <th>Single Phase AC</th> </tr> </thead> <tbody> <tr> <td>Under all specified Input, output conditions and load between 50 to 100%.</td> <td>better than 85%</td> </tr> </tbody> </table> <p>48V units:</p> <p>a) Rectifier rating < 50A</p> <table border="1"> <thead> <tr> <th>Condition</th> <th>Single Phase AC</th> </tr> </thead> <tbody> <tr> <td>At nominal input, output and full rated load</td> <td>better than 90%</td> </tr> <tr> <td>Other specified Input, output conditions and load between 50% to 100%.</td> <td>better than 85%</td> </tr> </tbody> </table>	Condition	Single Phase AC	Under all specified Input, output conditions and load between 50 to 100%.	better than 85%	Condition	Single Phase AC	Under all specified Input, output conditions and load between 50 to 100%.	better than 85%	Condition	Single Phase AC	At nominal input, output and full rated load	better than 90%	Other specified Input, output conditions and load between 50% to 100%.	better than 85%	Test Case-15
Condition	Single Phase AC															
Under all specified Input, output conditions and load between 50 to 100%.	better than 85%															
Condition	Single Phase AC															
Under all specified Input, output conditions and load between 50 to 100%.	better than 85%															
Condition	Single Phase AC															
At nominal input, output and full rated load	better than 90%															
Other specified Input, output conditions and load between 50% to 100%.	better than 85%															
3.3.6	Input Power Factor: The true input Power Factor at nominal	Test Case-15														

	input, output voltage and rated load shall be better than 0.98 and shall be better than 0.95 in any other working condition and load between 50% to 100%. Active Power factor correction only shall be employed for the purpose.	
3.3.7	Soft Start Feature and Transient Response:	
3.3.7.1	Slow start circuitry shall be employed such that FR/FC module input current and output voltage shall reach their nominal value within 10 seconds.	Test Case-16
3.3.7.2	The maximum instantaneous current during start up shall not exceed the peak value of the rectifier input current at full load at the lowest input voltage specified.	Test Case-16
3.3.8	Voltage overshoot/Undershoot: The requirements of this clause shall be achieved without a battery connected to the output of FR/FC module.	Information
3.3.8.1	The FR/FC modules shall be designed to minimise output voltage Overshoot/ Undershoot such that when they are switched on the DC output voltage shall be limited to +/-5% of the set voltage and return to their steady state within 20 ms for any load of 25% to 100%.	Test Case-16
3.3.8.2	The DC output voltage overshoot for a step change in AC mains from specified lowest to highest and vice-versa shall not cause shut- down of FR/FC module and the voltage overshoot shall be limited to +/- 5% of its set voltage and return to steady state within 20 ms.	Test Case-16
3.3.8.3	The modules shall be designed such that a step load change of 25 to 100% shall not result in DC output voltage Overshoot/ Undershoot of not more than 5% and return to steady state value within 10 ms without resulting the unit to trip.	Test Case-16
3.3.9	Total Harmonic Distortion :	

3.3.9.1	<p>Total Voltage Harmonic Distortion: The Total line harmonic voltage distortion shall not be more than 10% in conformity with CIGRE's limits</p> <p>Note: The above Harmonic Distortion limits are as per communication received from Central Electricity Authority vide their office letter No. GO2/Comm.I/1/1-95/962 dated 22.12.92.</p>	Test Case-15
3.3.9.2	<p>Total Current Harmonic Distortion: The total harmonic distortion shall be limited as per EN 61000-3-2 Ed.2:2000. The total current harmonic distortion contributed by the unit at the input shall not exceed 10% for input voltage range 170V-260V (for single phase units); , for load between 50 to 100% of the rated capacity.</p>	Test Case-15
3.3.10	<p>Current limiting (Voltage Droop): The Current limiting (Voltage Droop) shall be provided for Float/Charge operation. The float/charge current limiting shall be continuously adjustable between 50 to 100% of rated output current for output voltage range of -11.1V to -13.98V for 12V unit and -44.4 to -56 volts for 48V unit respectively. For test purposes upper limit of 100% + 5% and lower limit of 50% - 5% shall be acceptable.</p>	Test Case-17
3.3.11	<p>The float and charge current limit adjustment shall be provided, either on the front panel of the individual FR/FC module or through a provision at the centralised location on front panel of DSCA through a menu driven program capable of adjusting the float and charge current limits of the each FR/FC module individually, irrespective of the rating and number of modules located in the same rack or in other racks of the power plant for the ultimate capacity of the unit.</p>	Information
3.3.12	<p>The FR/FC modules shall be fully protected against short circuit. It shall be ensured that short circuit does not lead to any fire hazard. The unit shall start delivering output automatically when the short circuit is removed.</p>	Test Case-6

3.3.13	Load Sharing (Parallel operation):	
3.3.13.1	FR/FC modules shall be suitable for operating in parallel with one or more modules of similar type, make and rating, other output conditions remaining within specified limits.	Information
3.3.13.2	The current sharing shall be within +/- 10% of the average current per rectifier module in the unit (mounted in the same or different racks) when loaded between 50 to 100% of its rated capacity for all working conditions.	Test Case-18
3.3.13.3	In the event of failure of DSCA, FR/FC modules parameter shall not be disturbed. All the FR/FC modules shall take care of the load on default settings and share the load collectively.	Test Case-10
3.4	Electrical Protections :	
3.4.1	The charge controller shall for the control circuitry using solid state switching techniques to incorporate suitable protections (with a tolerance of +/- 1% in case of DC voltage & current) to safeguard circuit against the following conditions:	Undertaking to be taken from OEM,
3.4.2	<p>A) DC over voltage:</p> <p>(i)Charge controller: The output voltage of the charge controller shall be maintained in accordance with clause 3.2.2 . In case the charge controller output voltage exceeds 56.5 V for 48V power supply, 28.2 V for 24V power supply and 14.1 V for 12V power supply due to failure of the voltage control device provided to control the SPV Power Source voltage, the SPV power source shall be isolated automatically, creating alarm. Restoration of the SPV Power Source (MPPT) shall be through manual reset.</p> <p>(ii) SMPS: Shall be in accordance with relevant clause of TEC Standard No. 66110:2025 or latest</p>	Test Case-4
3.4.3	<p>Battery Under Voltage Isolation:</p> <p>For VRLA Battery:</p> <p>In case output DC voltage falls below 44.4V for 48V power</p>	Test Case-5

	<p>supply, 22.2V for 24V and 11.1V for 12V power supply, the battery shall be isolated from the load. The load shall automatically be reconnected, when the voltage is above 51.6V for 48V, 25V for 24V power supply and 12.5V for 12V power supply respectively</p> <p>For Li-ion Battery:</p> <p>In case output DC voltage falls below, between 11.2V to 11.6 V for 12V power supply, 22.4V to 23.2 V for 24V power supply, 42V to 44 V for 48V power supply, the battery shall be isolated from the load. The load shall automatically be reconnected, when the voltage is more than 12.8V for 12V power supply, 25.6V for 24V power supply, 48 V for 48V power supply respectively</p>	
3.4.4	<p>Reverse Polarity: There shall not be any damage to the components of the power supply in case the polarity is reversed. The unit shall start its normal function when the correct polarity is restored</p>	Test Case-6
3.4.5	<p>Reverse flow of current from the battery to the module: The circuit design shall ensure protection against the discharge of the Battery through the FR/FC & SPV power source (MPPT) module in any case.</p>	Test Case-6
3.4.6	<p>Over Load/Short Circuit :</p> <p>The unit shall be protected for over load/ short circuit. It shall be ensured that short circuit does not lead to any fire hazard.</p>	Test Case-6
3.4.7	<p>Battery Path Current Limiting: In Auto Mode the current in each battery path (For VRLA type battery) shall be settable as per the battery capacity and DG capacity as applicable so that the battery path current is kept at 5% to 10% of battery AH capacity. When Li-ion battery selected setting the current in each battery path should be settable as per the battery capacity and DG capacity as applicable so that battery path current is kept at 5% to 50% of battery AH capacity and actual</p>	Test Case-19

	<p>battery path current will be decided by the purchaser. Further, purchaser will give the capacity of the battery and DG set if applicable to be used for this purpose. For the type approval the manufacturer shall demonstrate the facility and undertake to make provision as per order.</p>	
3.4.8	<p>Fuses / circuit Breakers/MCB with current limiting devices : Suitably fault rated fuses or circuit breakers with current limiting devices shall be provided for the following :</p> <ul style="list-style-type: none"> i) Live AC input line. (Hybrid power supply only) ii) Negative DC output iii) Against failure of control sensing circuit. <p>Note: 1. Use of mechanical switching devices such as relays etc. is not permitted in the control circuit. MCBs are however, permitted for short circuit protection only.</p> <p>2. Two fuses /Circuit breakers/MCBs (minimum)of each type shall be provided with each unit. provided fuses are non-solderable and cartridge type.</p>	Test Case-6
3.4.9	<p>The circuit design shall be such that failure of components in the control circuit or the circuit itself shall result in the output voltage dropping to a value lower than the normal in order to prevent the possible damage to the equipment in such cases.</p>	Undertaking to be taken from OEM,
3.4.10	<p>Temperature Compensation for Battery: For VRLA: In auto float/charge mode there shall be provision for monitoring the temperature of battery and consequent arrangement for Automatic temperature compensation of the FR/FC ,FR/BC output voltage to match the battery temperature dependant charge characteristics. The output voltage of the rectifier in Float/Charge operation shall decrease or increase at the rate of 72mV (24 cells battery@ 3mV per cell) and 18mV (6 cells battery @ 3mV per cell) per</p>	Test Case-20

	<p>degree increase or decrease in temperature over the set voltage. The output voltage shall decrease till the open circuit voltage of the battery is reached. The open circuit voltage range shall be settable between 2.1V/cell to 2.2V/cell. At this voltage the power plant voltage get locked and further increase in temperature shall not decrease the voltage further. This voltage shall also remain locked till the temperature falls below the value corresponding to set value. When the output voltage reaches 55.8V (for 48V unit) and 13.98V (for 12V unit), due to increase in the output voltage owing to decrease in temperature, it shall get locked at this voltage and any further decrease in temperature shall not lead to further rise in the output voltage of the power plant. This voltage shall also remain locked till the temperature rises above the value corresponding to set value. A tolerance +/- 5 mV may be acceptable over the specified rate of 72mV/degree C. The nominal distance between the battery and power plant may be 20 metres. The manufacturer shall provide the necessary sensor and cord for the purpose with the power plant. Failure of temperature compensation circuit including sensors (including the open or short circuit) shall create an alarm and shall not lead to abnormal change in output voltage. Proper sign-writing shall be made in DSCA and both ends of temperature compensation cord for its easy termination.</p> <p>For Li-ion battery: Temperature compensation for battery should be disable when Li-ion battery selected. Temperature sensor is not required.</p>	
3.5	<p>Monitoring Alarms and Indicating Lamps: Visual indications/display shall be provided by means of “bright LCD/LEDs” on each FR/FC module and DSCA.</p>	Information
3.5.1	<p>Functional Indications: The following indications shall be provided to indicate mode in which the unit is functioning. In</p>	Test case-7

	<p>case of hybrid power supply the functional indications of FR/FC modules and DSCA:</p> <p>a) Mains available b) FR/FC, FR/BC On Auto Float c) FR/FC, FR/BC On Auto Charge</p> <p>Note: The functional indication a) shall be provided on both DSCA & FR/FC module, while b), c), may be provided either on DSCA or on both FR/FC and DSCA.</p>	
3.5.2	<p>Alarms Indications (both for Standalone and Hybrid Charge controller):</p> <ol style="list-style-type: none"> 1. Battery Low 2. Battery reverse polarity 3. Over load 4. Rectifier(s) Fail 5. Equipment Circuit Breaker Trip (if used) 	Test case-8
3.5.3	<p>Alarm Indications:</p> <p>A. On FR/FC:</p> <ol style="list-style-type: none"> a. LED Green - Healthy b. LED Amber - Warning c. LED Red – Major <p>B. On DSCA:</p> <ol style="list-style-type: none"> a) Load voltage High 12 unit : above 13.9V/Low below 11.4V 48 unit : above 55.6V/Low below 45.6V b) Alarms on FR/FC c) Mains Out of range d) System Over Load e) Mains "ON"/Battery Discharge f) Fan fail(in case fan provided at rack level) g) Temp. Sensor fail (for VRLA battery only) h) Battery Fail or No Battery (separate for each Battery) 	Test case-8

	<p>i) Battery isolated from the load</p> <p>j) Lightning and surge protection Stage II Fail</p>	
3.5.4	All the alarm circuits shall be provided with solid state technology. Use of electromechanical relays is precluded.	Information & Physical Check
3.5.5	All the alarms shall be DC only. All alarm circuits shall be provided with suitable delay to ensure that they do not operate to transients.	Physical Check
3.5.6	Every Alarm condition shall be accompanied with an audio alarm with a Auto/manual audio cut-off facility. In such cases, the visual indication shall remain active to signal the need for attention until the fault has been addressed and rectified.	Physical Check
3.5.7	All the protections/alarms shall be within tolerance of 0.25V in case of DC voltage and 1% in case of current. For AC voltage it shall be +/-5V.	Information
3.5.8	Two Potential Free Contacts (one for alarm and one redundant) shall be provided for extension of alarm to centralised display.	Test case-9
3.5.9	All Indications shall be suitably designated and there shall be provision for their easy identification from a distance of upto 3 meters.	Physical Check
3.5.10	Provision shall be made on the front panel of the charge controller to enable/disable the alarms/monitoring indications pertaining to the SMPS depending on, whether the charge controller is being used with standalone or hybrid power source.	Physical Check
3.6	Battery Health Check: There shall be a provision of monitoring the voltage, current, trickle current, temperature and conductance at a set periodicity(programmable) of the batteries associated with the power plant. There shall also be a provision of monitoring of each cell of the battery bank for voltage and temperature. The provision for conducting a	Test Case-11

	<p>partial discharge test (about 20%), of a pre-determined duration and frequency. During this test, current and voltage and temperature of each cell be recorded. Frequency and duration of partial test discharge shall be programmable. Conductance measurements/observations shall be off-line to prevent noise interference. The first observation of conductance, recorded by the power plant system, for the battery shall form the base value for future comparison. The provision of partial test discharge shall be implemented in such a way that at a time only one battery is put to discharge, so as to ensure that necessary battery reserve is available in case of power failure during or immediately after the test discharge. Provision shall be made for observing the state of charge of battery before commencing this test. In case the battery is not fully charged this test may be deferred till the battery is fully recouped.</p> <p>Any abnormality observed during above observations shall be highlighted by initiating an alarm. All the above information shall be made available to the remote site through RS 485 / RS 232 and Ethernet (Refer Clause 2.1.2 of this GR for specified protocol).</p> <p>Note: The manufacturer will give the list of hardware equipment required, for the purpose, at the time of procurement. Purchaser shall clearly indicate the requirement of battery health check feature while ordering the power plant. The manufacturer shall also undertake that the above provision will become fully functional by adding the hardware/software for the purpose, if ordered by purchaser.</p>	
3.7	<p>Remote control and monitoring: The power plant shall be RS 485/RS 232 and Ethernet(SNMP) compatible. It shall provide for the monitoring, alarm and control of the power plant and its</p>	Test Case-11

	associated batteries from a remote site through RS 485/ Rs 232 and Ethernet (SNMP). The exchange of information and protocol format between the power plant and remote site shall be as given in the Clause No. 1.3 of TEC GR 66110:2025.	
3.8	Battery Bank: The following batteries shall be suitable for SPV applications:	Information
3.8.1	The battery shall be 48V (24 cell) or 12V (6 cells) VRLA type (deep-cyclic) i.e. slow rate of charge and discharge conforming to TECGR TEC/GR/TX/BAT - 001/04.JUNE.2011 with amendments, if any. OR	Undertaking to be taken from OEM,
3.8.2	The battery shall be 48V (24 cell) or 12V (6 cells) Tubular VRLA based on GEL technology (deep-cyclic), conforming to TEC GR No. TEC/GR/TX/BAT - 003/02.MAR.2011 with amendments, if any. OR	Undertaking to be taken from OEM,
3.8.3	The battery shall be 48V or 12V Li-ion type (deep-cyclic) conforming to TEC GR: TEC/GR/TX/Li-ion - 001/01.MAR.2016 with amendments, if any.	Undertaking to be taken from OEM,
3.8.4	For 24 V (Standalone Application only), the batteries mentioned above in (i) or (ii) or (iii) of required capacity may be used.	Undertaking to be taken from OEM,
3.8.5	The capacity of the battery shall be so designed so as to supply the ultimate load during the non-sunlight hours i.e. during the night and also during the cloudy weather (Number of sunless days at a stretch as specified by the ordering authority) or when both SPV power and AC mains are not available with 80% reserved power in fully charged condition and shall be floated across the SPV panel or SMPS and load through charge controller.	Undertaking to be taken from OEM,
3.8.6	The nominal voltage of the Battery shall be 48V or 12V as per application. However, the actual capacity of the battery in	Information

	terms of Ampere-hour shall be calculated as per sample calculation sheet, placed at annexure 4, taking into consideration the actual load and the autonomy (refer chapter - 2 for ordering information of this document).	
3.8.7	<p>For VRLA Battery: The battery shall deliver at 120% of its rated capacity at low rate of discharge between C/20 and C/120. At discharge rate of C/120 or slower, the battery shall deliver at least 150% of its rated capacity.</p> <p>For Li-ion Battery: When a module is discharged at C/5 rate, it shall deliver 90% of rated capacity (corrected at 25°Celsius) before the module voltage reaches 12 for 12V battery, 24 for 48V battery & 45V for 48V battery. The capacity (corrected at 25°Celsius) shall also not be less than C (rated capacity) and not more than 120% of C (rated capacity) when discharged to the voltage of 11.2 for 12V battery, 22.4V for 24V battery & 42V for 48V battery.</p>	Test Case-5
4.0	QUALITY REQUIREMENTS:	
4.1	Components: The component parts of the equipment shall be of professional grade of the reputed manufacturers to ensure prompt and continuous service and delivery of spares. For use of CACT approved Components, Purchaser may clearly specify the requirement. The Peak Inverse Voltage (PIV) ratings of components used shall have a minimum rating of twice the maximum system voltage. Use of potentiometers is precluded. Switching components used at input side of the SMPS shall be rated at 600V (minimum).	Undertaking to be taken from OEM
4.2	Power transformers & Chokes: Power transformers & chokes shall use class B or higher grade of insulation. The transformers and chokes shall be wound with copper wire and provided with adequate insulation.	Undertaking to be taken from OEM
4.3	Fuses/MCBs with current limiting device or circuit breakers of	Physical check ,

	proper rating shall be provided wherever appropriate for protection of control/sensing circuit. Fuses/MCBs shall conform to BIS specification.	Undertaking to be taken from OEM
4.4	Component Approval : All the components, used, shall be CACT/NABL accredited Labs approved. Components shall neither be combustible nor shall support combustion.	Undertaking to be taken from OEM
4.5	<p>Quality and Workmanship :</p> <p>a) All the units of the system shall be manufactured in accordance with international quality management systems ISO-9001-2015 (latest issue), for which the manufacturer shall be duly accredited. A quality plan describing the quality assurance system followed by the manufacturer would be required to be submitted. The manufacturer shall also be accredited for the compliance of ISO 14001:2015 (latest issue) pertaining to environmental requirements.</p> <p>b) All the equipment shall be manufactured as per the latest QA Guidelines indicated in Quality Manuals QM-118 (Quality reliability in product design), Manuals QM-202 (Pictorial guidelines for Visual assessment of quality of printed board assemblies (PBA) and discrete terminal assemblies), QM-204 (Guidelines for workmanship standards for repair & modification of printed wiring board assemblies), QM-205 (Guidelines for standard of workmanship for printed boards), QM-206 (Guidelines for standard of workmanship for printed boards assemblies), QM-207 (Guidelines for soft solder and fluxes for Telecom Equipments) and QM-210 (Guidelines for standard of workmanship for surface Mounting Devices).</p> <p>c) All wiring shall be neatly secured in position and adequately supported. Metal panel or cover holes through which the wires or cables pass shall be suitably bushed.</p>	Documents/ Undertaking to be taken from OEM

	d) All materials and workmanship shall be of professional quality to ensure the MTBF requirements.	
4.6	Quality Assurance Tests: Each of the units supplied against the specific order after type approval shall be inspected and tested to ensure that the requirements of this document have been met. These tests shall be carried out by QA wing of BSNL	Physical Check
4.7	Module Replacement Time & MTBF	
4.8	MTBF(Mean Time between Failures): MTBF of the system shall not be less than 100,000 hours. The MTBF for fans shall be better than 70,000 hours at 40°C. The concurrence of CACT of QA wing of BSNL in this regard is mandatory.. The MTBF shall be verified as per QM-115. MTBF, predicted and observed values shall be furnished along with calculations by the manufacturer. Based on these figures three years maintenance spares shall be specified by the equipment supplier. The equipment availability shall be in excess of 99.9 %.	Documents/ Undertaking to be taken from OEM
5.0	ENVIRONMENT REQUIREMENTS:	
5.1	SPV module/panel/array, Charge Controller unit, SMPS (in case of hybrid power supply), Mounting structure and Batteries in compliance with the requirements of relevant clauses of 14016:2010 (old no. QM-333:2010) shall be capable of working in a saline atmosphere in coastal areas and shall be free from any corrosion at any period of time(IEC 61701 compliance may be provided). The SPV module/panel/array, charge controller, SMPS and battery shall also work with the guaranteed performance at an altitude in excess of 3000 metres above Mean Sea Level (MSL) in compliance with the relevant clauses of QM 333. These units	Test Result from Accredited Test Laboratories need to be submitted.

	shall also be capable of withstanding the rigors of transportation and storage and shall comply with the vibration, drop and topple test requirements as given in the relevant clauses of TEC 14016:2010 (old no. QM-333:2010).	
5.2	Environmental requirements for SPV Module/Panels: These environmental requirements should be complied as per:	Information
5.2.1	The SPV modules shall be soaked for at least for a week in natural sunlight before offering for tests or supply in accordance with the Instructions issued by the ministry of Non-Conventional Energy Sources to Test Centres vide letter No. 29(2)/Testing-97/PVTF dated 13.12.98. A sample check of 1% of the total modules offered will be carried out by QA wing of the respective Telecom operator.	Test Result from Accredited Test Laboratories need to be submitted.

DRAFT

5.2.2

In addition to the requirement of clause 5.2.1, the SPV modules shall also satisfy the following environmental test conditions:

S. No.	Tests	Test Condition	Reference/Specification
1.	Dry heat	+85 ° C 16 hours	IEC-68-2-2 Test Bb
2.	Cold	-40 ° C 16 hours	IEC-68-2-1 Test Ab
3.	Rapid Change of Temperature	-40 ° C to 80 °C 10 cycles	IEC-68-2-14
4.	Composite Temperature Humidity Cyclic Test	25° C to -10° C 25° C to 65° C 95% RH 10 cycles	IEC-68-2-38
5.	Rain	2 Hours	IS 9000 (PART 16)
6.	Heavy dust/sand storm	-	Clause 16.0 of QM-333
7.	Wind speed	200Kms/hour	-
8.	Hail Storm	Hails of 25mm dia size at 23m/Sec velocity shall not cause physical damage to any part of the solar array or associated structures.	-

	9.	Bending & twisting	module shall withstand a displacement at one corner by 20 mm/metre measured along with the shortest edge without open or short circuit within the module or suffer low resistance between terminals to frame.		
	10.	Insulation test for module	As per IEC : 61215	IEC : 61215	
	11.	Hot-spot endurance test	As per IEC : 61215	IEC : 61215	
	12.	Robustness of termination test	As per IEC : 61215	IEC : 61215	
	13.	Wet leakage current test	As per IEC : 61215	IEC : 61215	
	14.	Bypass diode thermal test	As per IEC : 61215	IEC : 61215	
5.3	Environmental requirements for Charge Controller and SMPS: In addition to the requirement of Clause 5.2 of this document, the charge controller and SMPS, shall operate at the specified rating and conform to the requirements contained in TEC 14016:2010(old no. QM 333:2010) Category B2.				Test Result from Accredited Test Laboratories need to be submitted.

5.4	<p>Burn-in Test: The Hybrid CCU or Standalone CCU shall be capable of withstanding a burn-in test for 72 hours at an ambient temperature of 50°C, when the equipment working at full rated load. This test may be performed in a temperature controlled room with free air flow. The ambient temperature shall be measured at a distance of 1 foot from the equipment under test. Necessary test set-up for the purpose shall be provided by the manufacturer.</p>	Test case-21
5.4.1	<p>The temperature rise of heat dissipating components above the ambient, measured directly or at the heat sink in the first 8 hours of the above test shall not be more than:</p> <p>Transformers & Chokes : 70°C for B grade of Insulation. For higher grade of insulation, higher temperature rise is permissible subject to the following conditions:</p> <ol style="list-style-type: none"> i. It is at least 20°C below the permissible limit for the grade of insulation. ii. The temperature rise shall be at least 30°C below the curie temperature of the magnetic material. iii. This temperature shall neither affect other components nor lead to fire hazard. <p>Semiconductor devices: 60°C or as per component specification.</p>	Test case-21
5.5	<p>Insulation Resistance and Voltage Proof Tests:</p>	
5.5.1	<p>Insulation Resistance : The insulation resistance of a fully wired FR/FC & MPPT Module, when tested with a 500V DC megger shall be given below :</p> <p>A) FR/FC</p> <ol style="list-style-type: none"> a) AC Input & Earth - Greater than 2 meg Ohm b) DC Output & Earth - Greater than 1 meg Ohm c) AC Input & DC output - Greater than 5 meg Ohm <p>B) MPPT</p> <ol style="list-style-type: none"> a) DC Input & Earth - Greater than 2 meg Ohm 	Test Case-22

	<p>b) DC Output & Earth - Greater than 1 meg Ohm</p> <p>c) DC Input & DC output - Greater than 5 meg Ohm</p>	
5.5.2	<p>Voltage Proof Test: The Voltage Proof Test of a fully wired FR/FC & MPPT Module with EMI/RFI capacitors and MOVs/Tranzorbs removed from the circuit a test voltage of 1500V/50Hz is applied for one minute.</p> <p>-Between earth and interconnected output terminals.</p> <p>-Between interconnected input and output terminals.</p> <p>Alternatively without removing EMI/RFI capacitors, the lightning protection circuitry and Tranzorbs etc., but with EMI/RFI discharge resistors removed :</p> <p>a) A 2150V DC can be applied for one minute between interconnected input & output terminals</p> <p>b) 650V DC can be applied for one minute between interconnected Input output terminals & earth.</p> <p>This DC voltage test is in accordance with UL 950 & IEC 62368-1 (IEC 950) Standards. No breakdown or abnormal temperature rise shall occur.</p>	Test Case-23
5.6	<p>Lightening Protection: The power supply shall be adequately protected against lightning at both AC input mains & SPV input side by a protection device, in a separate casing, attached on out side the charge controller in the following configuration:</p>	Information
5.6.1	<p>Protection of SPV Modules/Panels/Array: An external interceptor, with down conductor connected to proper earth, shall ensure the protection of the SPV modules/panels/array against direct lightning. It shall be installed at a distance of 0.5 metre (minimum). The cone of the protector shall be capable of providing protection to the whole SPV array and at the</p>	Declaration

	same time it shall not obstruct the sunlight to array. The external lightning protection shall be in compliance with Table 5, 6 and 7 of IEC 62305 –1.	
5.6.2	<p>Protection of Charge controller from SPV array side:</p> <p>Surge protection Device on input side of CCU shall consist of MOV surge-arrestors (Type1+2) connected between +ve and ground, –ve and ground. +ve and -ve in SPD(Type I & II) shall have mechanical indication on +ve, -ve and ground path for local indication and potential free / auxiliary contacts for remote indication. Type I+2 SPD shall be able to discharge total lightning impulse current (10/350 μsec) of 12.5KA SPD shall have Iscpv (short- circuit current rating) value as per the total SPV system current with a minimum value 1000A of Iscpv. SPD shall be able to discharge max current (8/20 μsec) of 40KA & nominal discharge current of 20KA (8/20 μsec).SPD shall have thermal Disconnection for fail safe operation SPD shall comply to the IEC 61643-31 standards and shall be certified from labs accredited by ILAC signatories or TEC designated labs as applicable</p>	Physical Check & Certificates issued by accredited test laboratories shall be submitted
5.6.3	<p>Protection on AC Main Side (Hybrid Power supply only):</p> <p>Stage-1 Lightning and Surge Protection is not in the scope of system. Stage-2 Lightning and Surge Protection for AC input of Site against the lightning and high voltage surges shall be as per GR of lightning and Surge Protection of Site (GR No. TEC 66130:2025). Purchaser may decide to buy Stage -1 & 2 protection devices for equipment safety against lightning and surges.</p>	Physical Check
6.0	GENERAL REQUIREMENTS	
6.1	<p>Radio Frequency Interference (RFI) Suppression:</p> <p>The system (FR/FC, FR/BC & DSCA modules) shall be designed to minimise the level of electromagnetic interference (EMI), both conducted and radiated, detected in its vicinity</p>	Certificates issued by accredited test laboratories shall be submitted

	and generated by the module and shall comply the following clauses :													
6.1.1	<p>Conducted and Radiated Emission from the single phase Power equipment.</p> <p>Name of EEMC Standard: CISPR 32 (2015) with A1(2019) “Electromagnetic compatibility of multimedia equipment – Emission requirements; Limits and methods of measurement of radio disturbance characteristics of Information Technology Equipment”.</p> <p>Limits: -</p> <p>i) To comply with Class A of CISPR 32 (2015) with A1(2019).</p> <p>ii) The values of limits shall be as per relevant tables under CISPR 32 (2015) with A1(2019).</p> <p>Test Procedure: Test setup, Test procedure & Measurements shall be conducted as per IEC- CISPR 32 (2015) with A1(2019).</p>	Certificates issued by accredited test laboratories shall be submitted												
6.1.2	<p>Electrostatic discharge (ESD) immunity limits:</p> <p>The limits shall be as per IEC 61000- 4-2, 9(1) (both Contact discharge method and Air discharge method) as given below:</p> <p>Test level:</p> <table border="1"> <thead> <tr> <th colspan="2">Contact discharge</th> <th colspan="2">Air discharge</th> </tr> <tr> <th>Level</th> <th>Test voltage (KV)</th> <th>Level</th> <th>Test voltage (KV)</th> </tr> </thead> <tbody> <tr> <td>4</td> <td>8</td> <td>4</td> <td>15</td> </tr> </tbody> </table> <p>Test Procedure: This test shall be conducted as per IEC 610004-2 for both requirements & unit shall comply of clause 9(1) of IEC 61000-4-2.</p>	Contact discharge		Air discharge		Level	Test voltage (KV)	Level	Test voltage (KV)	4	8	4	15	Certificates issued by accredited test laboratories shall be submitted
Contact discharge		Air discharge												
Level	Test voltage (KV)	Level	Test voltage (KV)											
4	8	4	15											
6.1.3	<p>Radiated radio-frequency Electromagnetic field immunity limits: The limits as per IEC 61000-4-3.</p>	Certificates issued by accredited test laboratories shall												

	<p>Test level:</p> <p>Test Procedure: This test shall be conducted as per IEC 61000-4-3. Test results shall be in compliance of clause 9(a)</p> <table border="1" data-bbox="308 521 1187 792"> <tr> <td colspan="2">Frequency range: 80 MHz to 1000 MHz.</td> </tr> <tr> <td>Level</td> <td>Test field strength V/m</td> </tr> <tr> <td>3</td> <td>10</td> </tr> </table> <p>of IEC 61000-4-3.</p>	Frequency range: 80 MHz to 1000 MHz.		Level	Test field strength V/m	3	10	be submitted											
Frequency range: 80 MHz to 1000 MHz.																			
Level	Test field strength V/m																		
3	10																		
6.1.4	<p>Electrical fast transient/Burst immunity limits: The limits shall be as specified in IEC 61000-4-4.</p> <p>Test level:</p> <table border="1" data-bbox="308 1039 1126 1610"> <tr> <td colspan="3">Open-circuit output test voltage (+/-10%) & repetition rate of impulses (+/-20%)</td> </tr> <tr> <td rowspan="2">Level</td> <td colspan="2">On Power supply port, Protection Earth</td> </tr> <tr> <td>Voltage peak KV</td> <td>Repetition rate KHz</td> </tr> <tr> <td>4</td> <td>4</td> <td>2.5</td> </tr> <tr> <td colspan="3">Rise time of one Pulse - 5 ns +/- 30%</td> </tr> <tr> <td colspan="3">Impulse duration - 50 ns +/- 30%</td> </tr> </table> <p>Test Procedure: This test shall be conducted as per IEC 61000-4-4. Test results shall be in compliance of clause 9(1) of IEC 61000-4-4.</p>	Open-circuit output test voltage (+/-10%) & repetition rate of impulses (+/-20%)			Level	On Power supply port, Protection Earth		Voltage peak KV	Repetition rate KHz	4	4	2.5	Rise time of one Pulse - 5 ns +/- 30%			Impulse duration - 50 ns +/- 30%			Certificates issued by accredited test laboratories shall be submitted
Open-circuit output test voltage (+/-10%) & repetition rate of impulses (+/-20%)																			
Level	On Power supply port, Protection Earth																		
	Voltage peak KV	Repetition rate KHz																	
4	4	2.5																	
Rise time of one Pulse - 5 ns +/- 30%																			
Impulse duration - 50 ns +/- 30%																			
6.1.5	<p>Surge immunity limits: The limits as per IEC 61000-4-5.</p> <p>Test level:</p> <table border="1" data-bbox="308 1944 1187 2000"> <tr> <td>Level</td> <td>Open circuit test voltage</td> </tr> </table>	Level	Open circuit test voltage	Certificates issued by accredited test laboratories shall															
Level	Open circuit test voltage																		

	<table border="1"> <tr> <td></td> <td>(+/- 10%) KV</td> </tr> <tr> <td>1</td> <td>0.5</td> </tr> <tr> <td>2</td> <td>1.0</td> </tr> <tr> <td>3</td> <td>2.0</td> </tr> <tr> <td>4</td> <td>4.0</td> </tr> </table> <p>Voltage surge - 1.2/50 μs Amplitude - 2 KV(DM) - 4 KV(CM) - After testing for 4KV, the amplitude shall also be increased to 6 KV (1.2/50 μs) Combined wave form as per IEEE C62.41- 1991 to cover Lightning/ Surge protection test also. - Test results shall be in compliance of clause 9(b) of IEC 61000-4-5.</p> <p>Test Procedure: This test shall be conducted as per IEC 61000-4-5. After testing for 4KV, the amplitude shall also be increased to 6 KV (1.2/50 μs) Combined wave form as per IEEE C62.41-1991(to cover Lightning/ Surge protection test also).</p> <p>Note: The rated voltage of the MOVs used for the above shall not be less than 320V.</p>		(+/- 10%) KV	1	0.5	2	1.0	3	2.0	4	4.0	be submitted
	(+/- 10%) KV											
1	0.5											
2	1.0											
3	2.0											
4	4.0											
6.1.6	<p>Radio-Frequency Conducted Susceptibility immunity limits: The limits as per IEC 61000-4-6. Test level:</p> <table border="1"> <tr> <td colspan="2">Frequency range: 150 KHz- 80 MHz</td> </tr> <tr> <td>Level</td> <td>Voltage level (e.m.f.)</td> </tr> <tr> <td>3</td> <td>10</td> </tr> </table>	Frequency range: 150 KHz- 80 MHz		Level	Voltage level (e.m.f.)	3	10	Certificates issued by accredited test laboratories shall be submitted				
Frequency range: 150 KHz- 80 MHz												
Level	Voltage level (e.m.f.)											
3	10											

	<p>Test Procedure: This test shall be conducted as per IEC 61000-4-6. Test results shall be in compliance of clause 9(a) of IEC 61000-4-6.</p>	
6.1.7	<p>Conducted Susceptibility Limits: Power equipment used in Telecom Network shall not malfunction when high voltage surge as specified below is superimposed at the input power mains to the power equipment, for more than two seconds as per IEC 61000- 4-18. The equipment shall also not fail or degrade in performance after the surge is withdrawn.</p> <p>Test levels:</p> <p>Voltage Rise time (First peak): 75 nano sec +/- 20%.</p> <p>Oscillation Frequencies: 100KHz & 1 MHz +/- 10%</p> <p>Repetition rate: at least 40/s for 100KHz and 400/s for 1 MHz</p> <p>Decaying: 50% of the peak value between the 3rd & 6th periods</p> <p>Burst duration: not less than 2s</p> <p>Surge amplitude: 250V (-10%) to 2.5 KV (+10%)</p> <p>Wave shape: Damped</p> <p>Test Procedure: Test set up, test procedure & Measurements shall be as per IEC 61000-4-18. EMI surge of specified levels injected on power leads of test sample shall not cause degradation of performance or malfunction.</p>	Certificates issued by accredited test laboratories shall be submitted
6.1.8	<p>At the time of Type approval the testing officer shall ensure that the power plant is in compliance of the clauses 6.1.1 to 6.1.7 given above.</p>	Information
6.2	<p>Noise and Vibration: The fully equipped Charge controller unit and SMPS rack, at full load, shall not contribute more than 15 dB (weighted) to the ambient noise level taken as 45dBA. It shall be measured at a distance of 1 metre from the rack and 1.25m above the floor level in the Acoustic Range. The</p>	Test Case-24

correction factor for Total Noise when the ambient noise level is more than 45dBA shall be as given below:

Ambient Noise	Correction Factor	Ambient Noise	Correction Factor	Ambient Noise	Correction Factor
45dBA	0dB	51dBA	1.41dB	57dBA	3.69dB
46dBA	0.18dB	52dBA	1.73dB	58dBA	4.17dB
47dBA	0.39dB	53dBA	2.07dB	59dBA	4.68dB
48dBA	0.61dB	54dBA	2.43dB	60dBA	5.21dB
49dBA	0.86dB	55dBA	2.82dB		
50dBA	1.12dB	56dBA	3.25dB		

Note: The correction Factor shall be added to the limit of 60dBA to arrive at the limit when the ambient is greater than 45dBA.

7.0	SAFETY REQUIREMENTS:	
7.1	The equipment shall conform to relevant safety requirements as per IS/IEC 61204: Part 7: 2016 as prescribed under Table no. 1 of the TEC document 'SAFETY REQUIREMENTS OF TELECOMMUNICATION EQUIPMENT": TEC10009: 2024'.	Certificates issued by accredited test laboratories shall be submitted
8.0	OTHER REQUIREMENTS:	
8.1	Rack: The rack structure shall be made up of rigid framework of steel profiles and shall be free of sharp edges or sharp corners. The structural strength of the rack shall be able to withstand the ultimate mechanical load capacity of the rack without any deformity. The rack shall have suitable ventilating arrangements (forced cooling from the sides is not permitted). The front door (if provided) and rear door may be of hinged or removable type. The gauge of metal sheet for load bearing part shall not be less than 1.5 mm and for rest of the parts shall not be less than 1.2mm. The unit may be floor-mounted	Physical Check and Declaration from Manufacturer

	or wall-mounted as specified by the purchaser. The unit may be either expandable or of ultimate size, as per purchaser's requirement". Sheet used in cabinet manufacturing should be Galvanized Iron (GI – 120gsm) & duly powder coated as per the colour given in clause no. 8.11.	
8.1.1	SPV Module/Panel: The mechanical design and construction of SPV modules, panels and mounting structure shall be inherently robust and rigid under all conditions of operation, adjustment, replacement, storage and transport. Sharp edges shall be avoided.	Undertaking to be taken from OEM
8.1.1.1	The cells shall be fully encapsulated and mounted behind a toughened low iron high transmission glass surface of thickness not less than 3 mm to protect the cells from moisture, dust and external environment. The contacts should be corrosion resistant. Crane/scrim glass shall be used inside the SPV module in order to help the evacuation process. Standard practice of using crane/scrim glass (not up to the edges) shall be adopted. The leads must be weather protected.	Physical Check
8.1.1.2	SPV modules shall be constructed of materials and component, which are known to be resistant to damage or deleterious change when exposed outdoors for a period of 15 years in any of the climatic conditions prevailing in India and provide mechanical and environmental protection to the encapsulated components. The possibility of attack by birds and animals shall be taken into account when selecting materials for the exterior of modules.	Undertaking to be taken from OEM, Test report
8.1.1.3	The modules shall have proven laminate construction. The laminates shall be sealed in a frame of light-weight anodised aluminium, with a suitable edge gasket/silicon rubber sealant to provide shock resistance and a further moisture barrier. The back surface shall be of impermeable aluminium	Certificates from accredited test labs are to be submitted

	foil/polyester and white refractive plastic material such as TEDLAR.	
8.1.1.4	The sealing of edges of glass on the frames shall be hermetically tight so that rain water and dew do not enter into the cell compartment.	Certificates from accredited test labs are to be submitted
8.1.1.5	A terminal box shall be attached to the SPV module frame. The terminal box should be resistant to moisture ingress and shall include integral by- pass diode to protect cell overheating due to localised shading. The module shall preferably be self draining and self cleaning.	Physical Check
8.1.1.6	The design of the solar module shall be multi-cell and modular in construction to provide the required output.	Physical Check
8.1.1.7	The SPV module is for use in terrestrial application and is to comprise of mono-crystalline/poly-crystalline silicon solar cells to be connected in series parallel arrangement. Each module shall be completely encapsulated and sealed to provide reliable operation under adverse climatic conditions.	Physical Check
8.1.1.8	The SPV modules, being used for Telecom supply, need to be characterised at NPL (National Physical Laboratory) or any other recognised Test Lab. In association with QA, BSNL for each type of cells used. The manufacturer will give the spread- in of silicon cells used by him.	Certificates from accredited test laboratories shall be submitted
8.1.2	The structure of the unit/rack shall be made up of rigid frame work of MS steel profiles with a proper ventilating arrangements. The structural strength of the framework shall be able to withstand the ultimate mechanical load of the unit/rack without any deformity. Unit/rack shall be free of sharp edges or sharp corners. The unit/rack shall have suitable ventilating arrangements (forced cooling from the sides is not permitted).The front door (if provided) and rear door may be of hinged or removable type. The gauge of metal	Physical Check and Declaration from Manufacturer

	sheet for panels shall not be less than 2mm. However purchaser may specify thickness/gauge of metal sheet to be less than 2mm for lower weight system, but quality and strength of the rack shall be ensured.	
8.1.3	<p>Proper thermal engineering of hardware design shall be done by the manufacturer so as to ensure the uninterrupted use of the equipment. Unit/rack, complete, with all panels fitted, shall be designed to allow cooling by natural convection. For the systems, using 25A & 50A FR-FC modules, forced cooling is permitted.</p> <p>For Outdoor racks, use of temperature-based speed-controlled DC Fans are only permitted for the purpose. There shall be an arrangement for automatic Switching-OFF of fans during AC input failure. If required, individual modules may be separated by air baffle to provide effective convection. The manufacturer shall also ensure that the failure of fan does not cause any fire hazard. The failure of any of the fans shall draw immediate attention of the maintenance staff. The filter used in outdoor cabinet shall be minimum of G3 grade.</p>	Information
8.1.4	To prevent the misuse of battery there shall be a provision for mounting the battery inside the charge controller, away from the heat generating components, if any. In such cases a provision of locking the charge controller which can be opened by a key or proper tool shall be made. However terminations for SPV power and Load with proper protection against accidental touch shall be accessible without opening the charge controller unit. If the above arrangement is not feasible due to large battery size the battery terminals shall be so designed to avoid its misuse. On input AC side 2 metre fire retardant cable of proper current rating with a 5A moulded 3 pin plug shall be provided.	Undertaking to be taken from OEM,
8.1.5	In case the battery is mounted inside the unit, the battery	Information

	mounting fixture shall be such as to hold the battery firmly in position in any orientation. Proper sign showing the orientation of the unit shall be marked.	
8.1.6	The unit shall be designed for easy maintenance & installation.	Undertaking to be taken from OEM,
8.1.7	Provision for mounting the Standalone CCU on the wall as well as table shall be provided. Hybrid CCU shall have the provision for fixing it on the floor.	Physical Check
8.1.8	The base of rack shall ensure uniform floor loading of not more than 975 kg/Sq. metre in case of Hybrid CCU & 320 kg/Sq metre.in case of Standalone CCU. Lifting facilities shall be provided by removable eyebolt located at the top of the rack. The necessary arrangement for fixing the rack on the floor shall be provided. The rack shall be provided with bottom clearance of 110 mm minimum or more.	Physical Check and Declaration from Manufacturer
8.1.9	Standalone CCU: The top of the rack shall be fully covered except for ventilation and bus bar or cable entries. Each air flow vent shall be covered by a grill to prevent foreign material larger than 5 mm dropping into the rack. Hybrid CCU: Rack shall be protected from dust & water complying to IP55 in accordance with IEC 60529.	Physical Check Certificates from accredited test labs need to be submitted for IP in accordance with IEC60529.
8.1.10	Standalone CCU: The rack shall be designed for easy maintenance & installation. Rack mounting arrangement shall provide easy access from front, rear and top for Installation and Maintenance. Hybrid CCU: The rack shall be designed for any maintenance and installation. Rack mounting arrangement shall provide easy access from front and rear for Installation and Maintenance.	Physical Check
8.1.11	The individual FR/FC modules shall be easily mounted to/removed from the front side of the rack. The FR/FC module	Physical Check

	shall be designed to slide into the rack on a suitable mechanical arrangement.	
8.1.12	The associated AC input, DC output connections, Control, alarms & interface cable connecting the modules shall be connected/disconnected easily without causing any interruption in the supply and damage to load or other working module.	Physical Check
8.1.13	Facility shall be made to connect external AC power at the bottom of rack and alarm cable & DC output distribution module at the top of the rack. Where cables pass through metal panels suitable bushing shall be provided to protect cables from damage. Bus-bars, if used, shall be suitably spaced, insulated and bushed(where it passes through holes) to prevent any possibility of short circuit between bus-bar and/or rack.	Physical Check
8.1.14	Standalone CCU: With doors in position, all Visual alarms and meters shall be clearly visible. In case of hinged door meters & alarm indications are permitted on door provided, the fixtures on the door do not restrict the movement of door in any way. Hybrid CCU: Meters and alarm indications (if any) shall remain inside the cabinet and shall not be positioned.	Physical Check
8.1.15	The FR/FC module shall either be cooled by natural convection or by forced cooling. Manufacturers should decide the cooling method of FR/FC modules based upon their design topology or cooling requirements if the purchaser as not mentioned any specific cooling requirements. Remarks: Cooling by natural connection increases the size of modules and make it very bulky.	Information
8.1.16	AC input to FR/FC modules shall be through composite type	Physical Check

	hot plug-in connectors. DC output shall be through hot plug-in connector on the FR/FC side and through lugged termination on the bus-bar/termination end. Control, alarm and monitoring connections shall only be through polarised connectors.	
8.1.17	The FR/FC module shall be removable from the front of the rack only. All AC input, DC output and alarm/control/monitoring cables interconnecting the modules and racks shall be easily connected/disconnected by plugs or connectors.	Physical Check
8.1.18	The Distribution/Switching sub-system of DSCA shall preferably be modular but Control, alarm and monitoring sub-system shall only be modular. The Distribution/ Switching sub-system may be accommodated in a rack with other FR/FCs. These sub-systems shall be rack mountable.	Physical Check
8.1.19	DSCA shall preferably be housed in the upper portion of the rack above the FR/FC and shall be equipped to meet the ultimate system capacity.	Physical Check
8.1.20	DSCA shall be provided for the ultimate system capacity as per clause 3.3.3.2 & 3.3.3.3. All AC, DC or control/alarm cabling/wiring shall be pre-wired for the ultimate SMPS capacity so that mere plugging-in of FR/FC module or connecting the additional panels shall add to the DC power output. It shall be ensured that the FR-FC modules are not site specific.	Physical Check
8.1.21	Mounting Structure of SPV ARRAY:	
8.1.21.1	A suitable hot dip galvanized iron structure shall be provided for mounting the module on any of the following locations :- a. roof top b. on the ground at an angle of tilt with horizontal an accordance with the latitude of the place of installation. c. on the Self Supporting Mast/Tower.	Undertaking to be taken from OEM
8.1.21.2	The steel for the mounting structure shall be a per IS 2062 :	Undertaking to be

	1992 & the galvanisation of the mounting structure shall be in compliance of IS 4759 latest issue.	taken from OEM
8.1.21.3	The mounting arrangement shall be suitable for column mounting or flat surface, as desired by the ordering authority.	Information
8.1.21.4	The Mounting structure shall be easily transportable and designed to withstand the wind speed of 200KM/hour. Design calculation shall be furnished to show that the proposed structure will withstand the wind speed of 200 Km/hr. The design for the mounting structure shall have the certification from a recognised or accredited Lab/Institution for the purpose. If required purchaser may reduce the wind speed requirement depending upon geographical condition of the site.	Undertaking to be taken from OEM
8.1.21.5	The mounting arrangement shall be suitable for pole (mast) mounting, column mounting or flat surface, as desired by the ordering authority.	Information
8.1.21.6	The exact mounting mechanism as well as the height of the mast (if required) shall have to be decided upon and specified by the ordering authority, as per the actual requirement at the site of installation and the same shall be mentioned in the purchase order (refer chapter-2 of this GR).	Information
8.1.21.7	Provision for directional and angular adjustment from North to South shall be made to ensure the optimum utilisation of incident sunlight. Three or more holes shall be provided to adjust the module seasonally.	Information
8.1.21.8	The design/drawings of the mounting structure shall be supplied along with the module to the purchaser.	Information
8.1.21.9	The mounting structure shall be suitably designed to withstand the weight of the panel/array.	Information
8.2	Terminations:	
8.2.1	A C Terminations:	

8.2.1.1	The input terminals shall be clearly marked as R, Y, B & N for three phase and L and N for single phase as applicable.	Physical Check
8.2.1.2	All the terminals, except AC earth, shall be electrically isolated. The terminal blocks shall be of Polyamide 6.6. To avoid any voltage drop at the connection points due to electrolytic thermal expansion, all metal parts should be non-ferrous including screws.	Physical Check
8.2.1.3	AC input termination shall be suitably protected against the accidental touch/contact with the working staff for their protection and shall also have clear and prominent "DANGER" marking. AC terminations shall be through standard finger safe lock-in type connectors conforming to BIS or any other international standard, with the concurrence of CACT. The use of nuts and bolts for AC termination is precluded.	Physical Check
8.2.1.4	Screening shall be provided between AC and DC components to prevent accident.	Physical Check
8.2.1.5	The AC input connection to the rectifier module shall be by a locking type hot plug-in connectors and socket arrangement.	Physical Check
8.2.1.6	All the connections between DSCA and FR/FC modules, shall be through proper rated cables only.	Physical Check
8.2.1.7	Fuses and Circuit-breakers for each FR/FC shall be easily accessible and properly rated.	Physical Check
8.2.1.8	Proper terminations for AC at the input of the circuit-breakers and its output to the FR/FC.	Physical Check
8.2.1.9	Nuts and bolts used for securing electrical connections shall not be used for clamping terminals to their mountings.	Physical Check
8.2.2	DC Terminations:	
8.2.2.1	Proper termination shall be provided in the Standalone CCU & Hybrid CCU to terminate the leads from the battery, load	Physical Check

	and cable from the SPV power source .	
8.2.2.2	At the input and output, proper rated fuses and circuit breakers shall be provided on the -ve lead from the unit. All DC +ve and -ve leads shall be clearly marked.	Physical Check
8.2.2.3	All conductors shall be properly rated to prevent excessive heating.	Physical Check
8.2.2.4	The terminals shall be capable to withstand the ultimate peak load.	Physical Check
8.2.2.5	The fuse or circuit-breakers with current limiting devices used, shall be easily accessible and properly rated.	Physical Check
8.2.2.6	The male connectors shall be mounted in the FR/FC module and female connectors be terminated to the cable.	Physical Check
8.2.2.7	The DC output to Battery and Load shall be through cable/bus-bars as per users requirement. However, for inter-rack connections, cables of proper rating are permitted.	Physical Check
8.2.2.8	Provision shall be made for interconnection between telecom equipment, Hybrid or standalone CCUs and batteries and including necessary switching arrangement . Additionally, appropriate terminations for telecom equipment, batteries, and Hybrid or Standalone CCUs shall be provided.The isolation of any of the battery from the load shall create an alarm.	Physical Check
8.2.2.9	All the AC, DC Control & alarm cabling shall be supplied with the rack.	Physical Check
8.3	Mounting of Component and Layout: Component mounting and fixing methods shall be secured Suitable mechanical structure/ arrangement for holding modules in position shall be provided so that the module is held firmly by sliding through it.	Information
8.4	Bus Bars: Tinned Bus-bars or tinned High conductive electrolytic copper strips with purity of 99.90% (min) as per BIS 613 latest issue, be able to withstand maximum Load	Undertaking to be taken from OEM & Test

	<p>current. The Bus-bar shall be capable to carry current density of 2 Amps/mm. Nuts & bolts shall be of stainless steel with tinned copper washers only. The size of bus-bars chosen for battery and load path shall be capable to take care of the current of maximum power plant capacity for which it is designed. The Bus- bar/cable size shall also ensure that the voltage drop between the output of the farthest FR/FC module riser and also between battery and exchange riser, as per the layout drawing shall be less than 500mV. The tinning shall be in compliance of IS 1359 : 1992 and its thickness shall be 10 μm (minimum).</p>	Case-25
8.5	<p>Cabling and Wiring : All insulated conductors except those within the confines of a printed circuit board assembly shall be of the rating enough to withstand the maximum current and voltage during fault and overload. All the wires and cables used shall be fire retardant as per IS 1554 with amendment 1 (June 94). All the cables & wires used shall also be Rodent & reptiles repellent. Uninyvin cables are also allowed to use in system. All wiring shall be neatly secured in position and adequately supported. Where wires pass through any part of metal panel or cover the hole through which they pass shall be suitably bushed.</p>	Physical Check
8.6	<p>Meters: For Hybrid CCU & Standalone CCU, there shall be a provision to monitor DC current as well as voltage of the System, any of the Battery, SPV array and that of the load with the help of Digital panel meter or LCD. In addition, provision shall also be made for Hybrid CCU to monitor AC voltage of the system and DC current as well as voltage with the help of Digital meters to read the voltage and current of the system, any of the battery or any of the individual FR/FC (at individual FR/FC</p>	Physical Check & Test Case-26

	<p>module also permitted). Digital meter's display/resolution should be such that it is clearly and unambiguously readable from a distance of 1 metre. Normally the meters shall indicate the System voltage and current.</p> <p>a. Current: +/- 1.5% of the range or better, shall be able to read up to full digit for meter range 50A & above and 1 place decimal for lower meter range.</p> <p>b. Voltage: +/- 1.5% of the range or better with a resolution of one decimal point in case of DC voltmeter and full digit in case of AC voltmeters. All the meters and shunts used for the above shall be CACT approved.</p>	
8.7	<p>Dimensions: Purchasing authority shall clearly specify the height of the rack as per his power room/equipment room requirements.</p> <ol style="list-style-type: none"> 1. Standalone CCU 2. Hybrid CCU 3. Battery Space required or not 	Information
8.8	<p>Earthing: Standalone CCU & Hybrid CCU rack shall be provided with earth terminals (two in each rack), in effective electrical contact with the body of the framework, shall be provided. All metal parts of the components, which do not carry current, shall be bonded thereto. Nominal cross-sectional area of earth continuity conductor, not contained within the cable, shall be half (minimum) of each current carrying conductor to be protected but in no case it shall be less than 3 mm diameter. Continuity conductor used for the purpose shall only be of copper. Suitable terminals shall be provided for terminating earth conductor.</p>	Physical Check
8.9	<p>Marking and Labelling : It shall be possible to locate each component on the PCB with the help of layout and circuit</p>	Physical Check

	<p>drawing. All terminals shall be properly sign written and all components properly labelled so that it shall be easy to identify them with reference to the supplier's instruction and installation manual. Designation of keys, switches and other components mounted on the front/inside panel and other operating positions shall clearly engraved or sign-written. Wiring shall be clearly & permanently identified with designation or a colour code which corresponds to circuit diagram. Where non-standard colours are used, cable functions shall be clearly & permanently labelled at both ends.</p>	
8.9.1	Fuse holder identification shall include details of fuse rating & type.	Information
8.10	Circuit & Cabling Diagram: A cabling diagram, screen printed, or any other better arrangement ensuring better life expectancy shall be placed ready reference of the maintenance staff.	Physical Check
8.11	Danger Label: There shall be a clear demarcation between the AC to DC converter unit and other components of the Charge controller. A Proper "Danger" warning shall be fixed on AC to DC conversion unit.	Physical Check
8.12	<p>Finish & Painting:</p> <p>a. Finish: The finish of the structure and panels shall conform to the latest issue of IS 101 and IS 168. The thickness of powder coating shall be between 60 to 100 Micron for indoor rack and 80 to 120 Micron for outdoor rack. The Colour used shall conform to IS 5 latest issue. The Colour using powder coating painting shall be as follows:</p> <p>Rack & Door - Satin Blue, No. 177</p> <p>Modules and inside - Shall harmoniously match the outside Colour</p> <p>Outdoor Rack: - Light Grey (RAL7035)</p>	Physical Check
8.13	Name Plate with the following details.	Physical Check

	<p>Name Plate for SPV Panel and Mounting Structure:</p> <ul style="list-style-type: none"> i) GR number ii) Name of the User iii) Manufacturer's name and identification mark iv) Name of the Item v) Model No. vi) Serial No. of the unit vii) Year of manufacture viii) TAC No. <p>Note: Anodised GR number and Name of the user may be provided on the back of the module frame.</p> <p>Name Plate for Charge Controller and SMPS unit/rack:</p> <ul style="list-style-type: none"> 1. Specification Number: 2. Type of the Unit: 3. Manufacturer's name and identification: 4. Model No.: 5. Unit Serial No.: 6. TAC No.: 7. Input voltage and phase (SMPS): 8. Output Voltage and Current (SMPS): 9. Year of manufacture: 10. Rating and Output voltage of the charge controller (MPPT): 11. Input Voltage of charge controller (MPPT): 12. Battery Capacity and voltage 	
8.13.1	<p>On the front top of the Charge controller cabinet and SMPS rack an anodised, screen printed or any other arrangement ensuring better life expectancy designation plate in 'BOLD' letters showing " 1 12V/...W or 24 V /...KW or 48V/....KW SPV POWER SUPPLY TELECOM EQUIPMENT WITH 12V OR 48V/ A SMPS USING ...A FR/FC MODULE" shall be provided as per the power supply specification</p>	Physical Check

	ANNEXURE - 3	
	SNMP and RS232/RS485 Modbus Communication Specifications for sequence of Exchange of information between hybrid SPV Power system & Remote Site monitoring equipment shall be as given in TEC GR 66110:2025 or latest.	Test Case-11

H. TEST SETUP & PROCEDURES:

Note:

- (a) The test set-up given in this document are tentative and may be changed by testing officer, considering, network/testers/ analyzer/simulator availability. In case of any discrepancy between this Test Guide and GR, GR clause shall prevail.
- (b) Since this is provisional Test Guide. Based on inputs received setup was prepared. Whenever the first testing was offered this provisional Test Guide would be revised.
- (c) Actual setup and tester/simulator may vary at the time of testing.
- (d) Testing of Solar Photo Voltaic (Spv) Based Standalone/ Hybrid Power Supply For Wi Fi Terminals & Other Similar Telecom Terminals will be done on the basis on testing facility available for testing Solar Photo Voltaic (Spv) Based Standalone/ Hybrid Power Supply For Wi Fi Terminals & Other Similar Telecom Terminals. If no testing facility is available for testing Solar Photo

Voltaic (Spv) Based Standalone/ Hybrid Power Supply For Wi Fi Terminals & Other Similar Telecom Terminals, then undertaking from OEM may be taken.

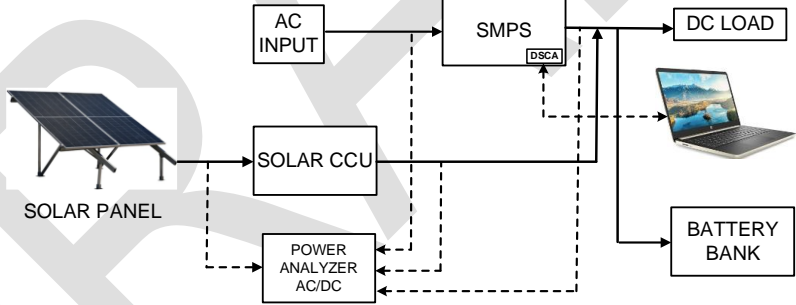
Test No.	Test Case-1
Test Details	Clause no. 2.1.2.1, 3.0, 3.1
Test Setup	 <p>The diagram illustrates the test setup for a hybrid power supply system. It includes a Solar Panel connected to a Solar CCU, an AC Input connected to an SMPS, a DC Load, a Battery Bank, a DSCA (Digital Signal Controller) connected to the SMPS and a laptop, and a Power Analyzer AC/DC connected to the AC input and the DC load.</p>
Test Procedure	<ol style="list-style-type: none"> 1. Connect AC input supply for SMPS section & DC supply for Solar CCU section. Also connect Battery and DC load. 2. Connect Laptop to DSCA to monitor system parameter. 3. Monitoring of system alarm, parameter over DSCA display. 4. System information on DSCA SW version, FR/FC SW version, module rating, Battery detail.

Test limits	<ol style="list-style-type: none"> FR/FC module rating, Controller information should be as specified in GR. Monitoring & setting of all parameter shall be through DSCA. Provision to switch off SMPS output. This can be done using a control signal from Charge controller which controls SMPS or a switch. DSCA shall have menu for selection of type of battery between VRLA and Li-ion battery and type of battery should be displayed on DSCA
Expected Results	<p>Check FR/FC module rating and parameter as specified in GR.</p> <p>SMPS output will be switched off through control signal from DSCA.</p>

Test No.	Test Case-3(Efficiency)
Test Details	Clause no. 3.2.1, 3.2.2, 3.2.3
Test Setup	<pre> graph LR DS[DC SOURCE] --> SCMS[SOLAR CHARGER MODULE/MPPT] PA[POWER ANALYZER AC/DC] -.-> DS PA -.-> SCMS SCMS --> DL[DC LOAD] SCMS -.-> P[Psophometer] </pre>
Test Procedure	<ol style="list-style-type: none"> Connect DC supply at the input & DC Load at the output of Solar CCU section. Connect Power analyzer between DC input and DC Output of Solar Charger Module/MPPT. Connect Psophometer at output of Solar Charger Module/MPPT to measure Psophometric noise. Measure efficiency of Solar Charger /MPPT module separately as per GR.

Test limits	1. Efficiency: $\geq 93\%$ 2. Psophometric Noise: $\leq 2\text{mV}$ with Battery connected.
Expected Results	Check system performance and limit as specified in GR.

Test No.	Test Case-4 (Protection)
Test Details	Clause no. 3.4.2 (DC Overvoltage)
Test Setup	<p>The diagram illustrates the test setup for DC Overvoltage protection. It includes a Solar Panel or DC Source, a Solar CCU (Charge Controller Unit), an SMPS (Switching Mode Power Supply) with a BSCA (Battery Safety Control Actuator), a DC Load (represented by a laptop), a Battery Bank, and a Power Analyzer AC/DC. The Solar Panel or DC Source is connected to the Solar CCU, which is connected to the SMPS. The SMPS output is connected to the DC Load and the Battery Bank. The Power Analyzer AC/DC is connected to the input and output of the SMPS to monitor power flow.</p>

Test Procedure	<p>Solar Charger MPPT :</p> <ol style="list-style-type: none"> 1. Connect DC supply at the input of Solar Charger (MPPT) 2. Connect multimeter or analyzer at the output of Solar charger. 3. Connect Laptop to DSCA to monitor system parameter. 4. Increase the output voltage of Charge Controller Module with the help of DSCA ≥ 56.5 V for 48V, 28.2 V for 24V and 14.1 V for 12V power supply & wait for Charge Controller Module/MPPT to isolated automatically. <p>FR/FC Module:</p> <ol style="list-style-type: none"> 1. Connect AC supply at the input of SMPS section. 2. Connect multimeter or analyzer at the output of SMPS. 3. Connect Laptop to DSCA to monitor system parameter. 4. Increase the output voltage of FR/FC module with the help of DSCA ≥ 56V (for 48V unit) and 14V (for 12V unit) & wait for FR/FC Module to isolated automatically.
Test limits	<ol style="list-style-type: none"> 1. In case the Charge Controller Module output voltage exceeds 56.5 V for 48V power supply, 28.2 V for 24V power supply and 14.1 V for 12V, the module will isolate automatically. 2. In case the FR/FC Module output voltage exceeds 56V (for 48V unit) and 14V (for 12V unit), the module will isolate automatically 3. Restoration of the module shall be through manual or through DSCA.
Expected Results	Both Charge Controller Module & FR/FC Module will isolate automatically once output voltage reach the define limit in GR
Test No.	Test Case-5
Test Details	Clause no. 3.4.3 (Battery Under Voltage), 3.8.7
Test Setup	

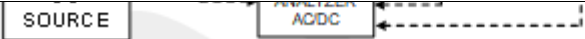
	
Test Procedure	<ol style="list-style-type: none"> 1. Switch off the AC & DC input supply. DSCA should be power up only on battery voltage. 2. Apply load on output & wait for battery to discharge & Voltage to falls below value define in respective GR clause for VRLA & Li-ion battery.
Test limits	In case output DC voltage falls below define limit in respective GR clauses, the battery shall be isolated from the load.
Expected Results	The battery will be isolated from load.

DRAFT

Test No.	Test Case-6 (Overload/Short Circuit)
Test Details	For Clause no. 3.3.12, 3.4.4, 3.4.5, 3.4.6, 3.4.8
Test Setup	<p>The diagram illustrates the test setup for an overload/short circuit test. It consists of two parts. The upper part shows an AC supply with lines L, N, and E connected to a box labeled 'RECTIFIER'. The output of the rectifier is connected to a circuit breaker labeled 'MCB > RM RATING', which is then connected to a 'MULTI-METER'. The lower part shows a 'DC INPUT' with '+' and '-' terminals connected to a box labeled 'Solar Charger Module/MPPT'. The output of this module is connected to another circuit breaker labeled 'MCB > MPPT RATING', which is also connected to a 'MULTI-METER'.</p>
Test Procedure	<ol style="list-style-type: none"> 1. Connect nominal AC supply/DC supply at FR/FC or MPPT module separately. 2. Terminate DC output (+ & -) both at single MCB (MCB rating should higher than module rating to avoid trip during short circuit condition). 3. Now switch on AC /DC input supply and check DC Output voltage. Input Voltage should be nominal. Now switch on MCB connected at DC output of module. 4. Check DC output Voltage with multimeter, it should be zero. 5. When test complete, switch off MCB and DC output should be nominal.
Test limits	Ensure that short circuit shall not lead to any excessive temperature rise or fire Hazard.
Expected Results	Check system performance and limit as specified in GR

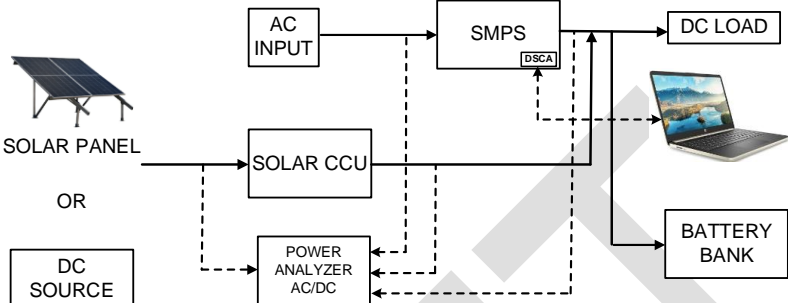
Test No.	Test Case-7 for Functional Indication
Test Details	For Clause no. 3.5.1
Test Setup	
Test Procedure	<ol style="list-style-type: none"> 1. Connect AC input to SMPS section & DC input to Solar CCU section. Connect DC load at the output of system. 2. Connect Laptop to DSCA to change or monitor parameter or through controller display. 3. Switch on AC input mains supply and check indication over DSCA and FR/FC. 4. Check FR/FC in auto float/Charge mode. 5. Check battery is charging & Load is on battery.
Test limits	<ol style="list-style-type: none"> 1. Mains available shall be provided on both DSCA & FR/FC Module 2. FR/FC On Auto Float, FR/FC On Auto Charge, Battery charging & Load on battery may be provided either on DSCA or on both FR/FC & DSCA.
Expected Results	All above alarm indication shall be available on DSCA or FR/FC module as specified in GR.

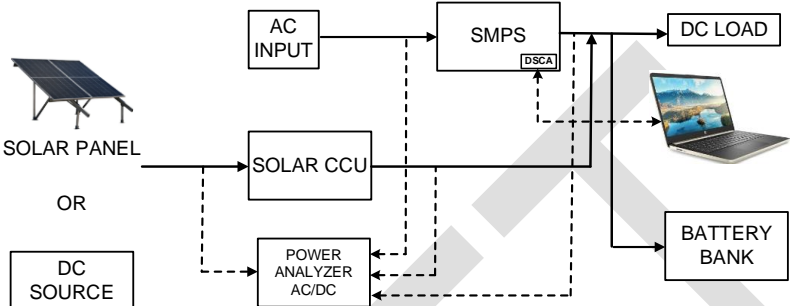
Test No.	Test Case-8 Indication
Test Details	For Clause no. 3.5.2, 3.5.3
Test Setup	
	<ol style="list-style-type: none"> 1. Connect AC input to SMPS section & DC input to Solar CCU section. Connect DC load at the output of system 2. Connect Laptop to DSCA to change or monitor parameter or through controller display. 3. Check LED indication over FR/FC module for <ol style="list-style-type: none"> a. LED Green - Healthy b. LED Amber - Warning c. LED Red – Major 4. Switch off MCB of any one rectifier & check alarm on DSCA. 5. If MCB is provided for Load equipment's then switched Off any one MCB & check alarm on DSCA. 6. On DSCA increase voltage to 56V/13.9V for load voltage high and 45.6V/11.4 for load voltage low corresponding to 48V/12V system. Then check system performance. 7. Increase/decrease AC input voltage and check alarm for Mains out of range on DSCA 8. Increase DC load to check system overload alarm on DSCA.

	<ol style="list-style-type: none"> 9. For Mains On/and battery discharge test, increase DC load over the system capacity and check alarm on DSCA. 10. For OD system (if applicable), while FAN running, stop one FAN manually for FAN fail alarm at rack level. 11. Remove temp sensor and check Temp sensor fail alarm on DSCA. 12. With DSCA setting, disconnect BLVD and check battery isolation or no battery over DSCA. 13. Remove one MOV from SPD & then check alarm on DSCA.
Test limits	<ol style="list-style-type: none"> 1. LED indication shall be available on FR/FC module 2. DC Over Voltage alarms shall operate within + or – 0.25Volts of the nominal set value. 3. Overload, Mains On & Battery discharge alarm will be available on DSCA. 4. Fan fail, Temp sensor fail alarm will be available on DSCA. <p>The above limits may be taken as reference only. For the actual limits the relevant Clauses of the latest TEC GR with amendments if any, shall be referred.</p>
Expected Results	All indication and alarm shall be available on FR/FC module or DSCA as specified in GR.

Test No.	Test Case-9 (Potential Free Contacts)
Test Details	Clause no. 3.5.8
Test Setup	<p>The diagram illustrates the test setup. It features a Solar Panel or a DC Source connected to either a Solar CCU (Charge Controller Unit) or a Power Analyzer AC/DC. The Solar CCU is connected to the SMPS (Switching Mode Power Supply) section. The SMPS section includes a DSCA (Digital Signal Controller/Analyzer) block. The output of the SMPS is connected to a DC Load, a Laptop, and a Battery Bank. A Power Analyzer AC/DC is also connected to the SMPS output for monitoring.</p>
Test Procedure	<ol style="list-style-type: none"> 1. Connect AC input to SMPS section & DC input to Solar CCU section. Connect DC load at the output of system 2. Connect Laptop to DSCA to change or monitor parameter or through controller display. 3. Generate PFC alarm as specified in GR.
Test limits	PFC alarm shall be as per GR.
Expected Results	Check PFC as specified in GR.

Test No.	Test Case-10
Test Details	Clause no. 3.3.13.3
Test Setup	
Test Procedure	<ol style="list-style-type: none"> 1. Connect AC input to SMPS section & DC load at the output of system. 2. Connect laptop to DSCA or through controller display to monitor rectifier parameter and alarms. 3. Turn on AC input supply, check default voltage of rectifier. Now turn on DC load and check load sharing. 4. Now remove controller to check rectifier default voltage and same load must be supplied by the rectifier. DC load should remain power on.
Test limits	<ol style="list-style-type: none"> 1. In the event of failure of Microprocessor or DSCA, FR/FC modules parameters shall not be disturbed. 2. All the FR/FC modules shall take care of the load on default settings and share the load collectively.
Expected Results	Check system parameter and limit as specified in GR

Test No.	Test Case-11
Test Details	Clause no. 3.6, 3.7, & Annexure-3
Test Setup	
Test Procedure	<ol style="list-style-type: none"> 1. Connect AC input to SMPS section & DC input to Solar CCU section. Connect DC load at the output of system. 2. Connect Laptop to DSCA to check system parameter load or through DSCA display. 3. Check DSCA and FR/FC SW version. 4. Monitor the SMPS & battery parameter on SNMP or RS-485/RS-232 as applicable as per GR.
Test limits	The system shall be RS 485/RS232 and Ethernet (SNMP Protocol) compatible, if remote monitoring is required. It shall be feasible to set any monitoring control parameter from a remote site
Expected Results	Check system parameter and limit as specified in GR.

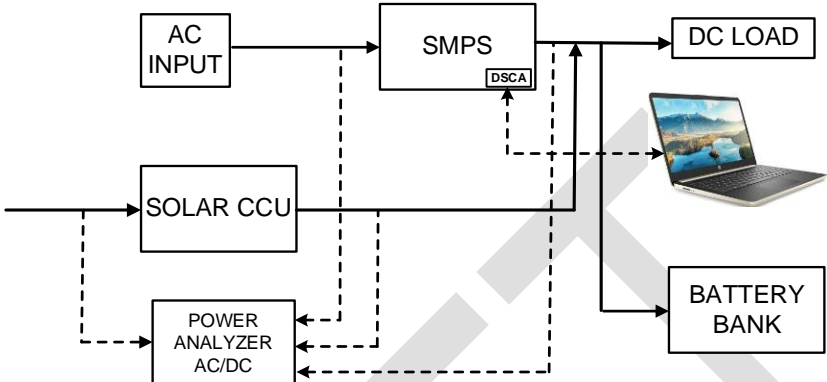
Test No.	Test Case-12 (AC input Supply)
Test Details	Clause no. 3.3.4.1
Test Setup	
Test Procedure	<ol style="list-style-type: none"> 1. Connect AC input to SMPS input and DC load to output of SMPS. 2. Connect Laptop to change or monitor system parameter and performance. 3. Connect power analyzer at AC input, DC output and battery. Apply Single Phase AC input nominal supply 230 V with variation in the range of +10% and -15% and frequency as 50 Hz +/-2Hz. Also supply AC input from 170 to 260 V and frequency as 50 Hz +/-2Hz. 4. While increasing/decreasing AC input on above specified range with tolerance, FR/FC module will shut down with RED LED indication on the same. 5. Mains Fail alarm will generate on DSCA in above case during shutdown. 6. When AC input becomes nominal, FR/FC module operate and will charge battery and will power up DC load.
Test limits	<ol style="list-style-type: none"> 1. Power Plant should deliver DC output voltage as per define range in GR. 2. Hysteresis within specified working limits shall prevent shutting down of the FR/FC. A tolerance of +/-5V is acceptable for

	<p>protection and alarm operation. Reconnection shall occur at a voltage, 10V lower than the set voltage for high isolation limit and 10V higher than the lower set limit to avoid hunting. The circuitry used for sensing the voltage for operation of isolation/reconnection device shall be able to withstand a voltage 15% higher than the specified extreme limit of isolation.</p>
<p>Expected Results</p>	<p>Power plant will work as normal during cut in after high/low cutoff range as specified in GR</p>

DRAFT

Test No.	Test Case-13 (Auto Float Mode & Charge Mode)
Test Details	Clause no. 3.3.4.3.1, 3.3.4.3.2, 3.3.4.4.1, 3.3.4.4.2
Test Setup	
Test Procedure	<ol style="list-style-type: none"> 1. Connect AC input to SMPS input and DC load to output of SMPS. 2. Connect laptop to DSCA to change current limit or through DSCA display. 3. Check battery is fully charged and in Float. 4. Now change Float voltage to 13.5/54V, 12/48V & 14/56 for respective 12V or 54V system & check Voltage on DSCA. 5. Now discharge battery so it can charge with more the 5% current of its capacity & goes into auto Charge mode. Now similarly to point-4 change Charge voltage to 14.2/55.2V, 12/48V & 14.6/56 for respective 12V or 54V system & check Voltage on DSCA. 6. Battery charging current limit shall be adjustable through Laptop or DSCA display.
Test limits	<p>FR/FC modules Voltage should increase or decrease as per setting done through DSCA.</p> <p>For 12V/48V FR/FC (Auto Float Mode): settable between -12V and -14V settable between -48V and -56V</p> <p>For 12V/48V FR/FC (Auto Charge Mode): settable between -12V and -14.6V settable between -48V and -56V</p>
Expected Results	Check system parameter and limit as specified in GR.

Test No.	Test Case-14
Test Details	For Clause 3.3.4.5
Test Setup	
Test Procedure	<ol style="list-style-type: none"> 1. Connect AC input supply to SMPS section and connect DC load. 2. Connect Power analyzer between AC input and DC Load. 3. For load regulation test, provide nominal AC input voltage 230Vac to SMPS. Once DC voltage build up, connect DC load of 25% of full capacity. 4. Now measure DC output voltage. 5. In above test at same AC supply, now increase DC load to 100% and measure DC output voltage.
Test limits	The DC output voltage at the terminals shall be maintained within +/- 1% of the half load preset voltage from 25% load to full load condition when measured over the full-specified input range.
Expected Results	Check system parameter and limit as specified in GR.

Test No.	Test Case-15 (Efficiency, P.F. Harmonics)
Test Details	For Clause no. 3.3.5, 3.3.6, 3.3.9.1, 3.3.9.2
Test Setup	
Test Procedure	<ol style="list-style-type: none"> 1. Connect Power analyzer between AC input and DC Output of FR/FC. 2. Connect Oscilloscope at output of FR/FC to measure ripple. 3. Measure efficiency of FR/FC module separately as per GR. 4. measure input power factor on power analyzer. 5. Measure Psophometric Noise with Psophometer. 6. Measure V_{thd} & I_{thd} through power analyzer.
Test limits	<ol style="list-style-type: none"> 1. CHD \leq 10% 2. VHD \leq 10% 3. Peak to Peak \leq 300mV 4. Psophometric Noise \leq 4mV without Battery connected & \leq 2mV with Battery connected. 5. Float Voltage: 54.0V. 6. Charge Voltage: 55.2V. 7. Efficiency: As prescribed in the clause no. 3.8 8. Power factor: As prescribed in the clause no. 3.9
Expected Results	Check system performance and limit as specified in GR

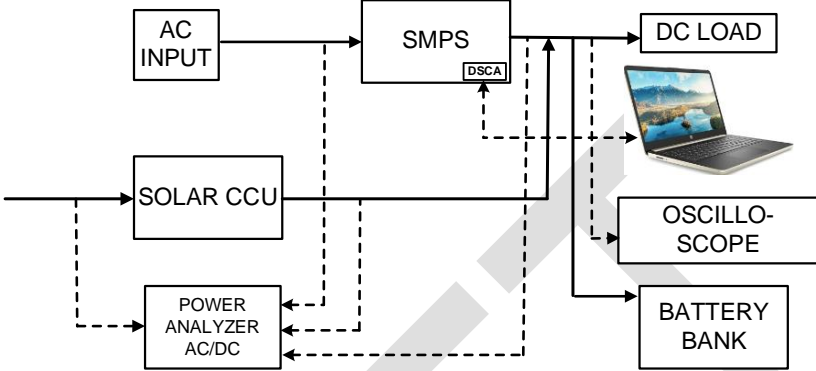
Test No.	Test Case-16(Soft Start, Voltage Over/Undershoot)
Test Details	For Clause no. 3.3.7.1, 3.3.7.2, 3.3.8.1, 3.3.8.2, 3.3.8.3
Test Setup	
Test Procedure	<ol style="list-style-type: none"> 1. Connect AC input supply to SMPS. 2. Connect power analyzer between AC input and DC output to Battery & DC load of SMPS. 3. Connect Laptop on DSCA or through DSCA display to change RM output voltage 4. Measure transient response as per respective clause when load switch ON 5. Now change in AC input through AC source as per GR and respective clause and output voltage of SMPS. 6. Now change AC input voltage of SMPS through AC source and check output voltage of SMPS for overshoot and undershoot at specified load mention in GR.
Test limits	<ol style="list-style-type: none"> 1. The Step Load change of 25 to 100% shall not result in DC output voltage Over Shoot / Under Shoot of not more than + / - 5% and return to steady state value within 10mS without resulting the unit to trip. 2. If value not capture in CRO then write you observation (not traceable).

Expected Results	Check system performance and limit as specified in GR.
Test No.	Test Case-17 (Current limiting (Voltage Droop))
Test Details	Clause no. 3.3.10
Test Setup	
Test Procedure	<ol style="list-style-type: none"> 1. Connect AC input supply to SMPS section and DC Load to output of SMPS section. 2. Connect Laptop on DSCA or through DSCA display to change FR/FC output voltage. 3. Set current limit from 50% from 100% & DC output of rectifier from 44.4V to 56V through DSCA. For test purposes upper limit of 100% + 5% and lower limit of 50% - 5% shall be acceptable. 4. FR/FC Modules goes in Current limit & voltage will droop while increasing the load. 5. Overload protection test will also be applicable with this test.
Test limits	<ol style="list-style-type: none"> 1. Shall be settable between 50% to 100% of rated Output Current (45% to 105% for test purpose) for Output Voltage range of -44.4V to -56.0V. 2. Further increase in Load shall not increase the Current and should result only in further Voltage Droop.
Expected Results	Check system parameter and limit as specified in GR.

Test No.	Test Case-18 (Load Sharing)
Test Details	Clause no. 3.3.13.2
Test Setup	
Test Procedure	<ol style="list-style-type: none"> 1. Connect AC input supply to SMPS section and connect DC load. 2. Connect Laptop to DSCA to check module sharing load or through DSCA display. 3. Turn on AC supply and DC load. 4. Check FR/FC module sharing load from 50% to 100% with float & charge voltage mode.
Test limits	The current sharing shall be within +/- 10% of the average current per rectifier module in the unit (mounted in the same or different racks) when loaded between 50 to 100% of its rated capacity for all working conditions.
Expected Results	Check system parameter and limit as specified in GR.

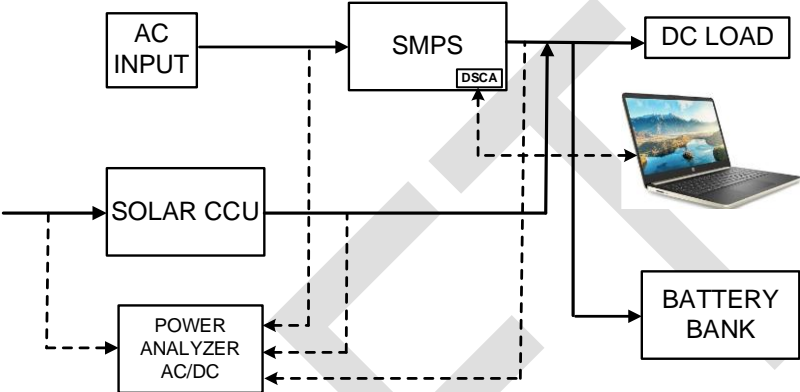
Test No.	Test Case-19 (Battery Path Current Limit)
Test Details	Clause no. 3.4.7
Test Setup	
Test Procedure	<ol style="list-style-type: none"> 1. Connect AC input supply to SMPS section and connect DC load. 2. Connect laptop to DSCA to change current limit or through DSCA display. 3. Set battery charging limit (5% - 10%) in step as per AH capacity for VRLA Batteries & take reading. And Set charging limit at (5% - 50%) in step as per AH capacity for Li-ion Batteries & take reading.
Test limits	<p>Auto Mode the current in each battery path (For VRLA type battery) shall be settable as per the battery capacity and DG capacity as applicable so that the battery path current is kept at 5% to 10% of battery AH capacity.</p> <p>When Li-ion battery selected setting the current in each battery path should be settable as per the battery capacity and DG capacity as applicable so that battery path current is kept at 5% to 50% of battery AH capacity</p>
Expected Results	Check system parameter and limit as specified in GR

Test No.	Test Case-20 (Temp Compensation)
Test Details	Clause no. 3.4.10
Test Setup	
Test Procedure	<ol style="list-style-type: none"> 1. Connect AC input supply to SMPS. 2. Check system voltage at different temperature during float & charging operation. The voltage will increase when temp decrease and vice versa 3. as per value provided in GR. 4. Check mV also at different temperature range as per test cases.
Test limit	<ol style="list-style-type: none"> 1. The output voltage of the rectifier in Float/Charge operation shall decrease or increase at the rate of 72mV (3mV/cell, 24 cell battery) per degree increase or decrease in temperature over the set voltage. 2. The open circuit voltage range shall be settable between 2.1V/cell to 2.2V/cell 3. When the output voltage reaches 55.8V, due to increase in the output voltage owing to decrease in temperature, it shall get locked at this voltage & any further decrease in temperature shall not lead to further rise in the output voltage of the power plant. 4. A tolerance of +/- 5mV may be acceptable over the specified rate of 72mV/deg C. 5. The above limits may be taken as reference only. For the actual limits the relevant Clauses of the latest TEC GR with amendments if any, shall be referred

Expected Results	Check system performance and limit as specified in GR
------------------	---

Test No.	Test Case-21 (Burn-in Test)
Test Details	Clause no. 5.4, 5.4.1
Test Setup	
Test Procedure	<ol style="list-style-type: none"> 1. Connect AC input supply to SMPS section & DC supply to CCU section. Connect DC load to output of system. 2. Connect thermocouple as per detail mention in GR. 3. Data should be logged as per detail mention in GR.
	<p>The temperature rise of heat dissipating components above the ambient, measured directly or at the heat sink in the first 8 hours of the above test shall not be more than</p> <p>a) Transformers and Chokes: 70°C for B grade of Insulation. For higher grade of insulation, higher temperature rise is permissible subject to the following conditions:</p> <ol style="list-style-type: none"> i) It is at least 20°C below the permissible limit for the grade of insulation. ii) The temperature rise shall be at least 30°C below the curie temperature of the magnetic material. iii) This temperature shall neither affect other components nor lead to fire hazard. <p>b) Semiconductor devices: 60°C or as per component specification.</p>
Expected Results	<p>The Unit under test shall be subjected to Heat run for 72 Hours of Elevated Burn-in at 50°C & full load.</p> <p>Heat run must be completed without failure of FR/FC, MPPT,</p>

	DCSA & any fire hazard.
--	-------------------------

Test No.	Test Case-22 (Insulation Resistance Test)
Test Details	Clause no. 5.5.1
Test Setup	
Test Procedure	<ol style="list-style-type: none"> 1. Short AC input terminal and DC output terminal separately as shown in figure A, B & C. 2. Connect insulation tester between shorting terminal of AC input and DC output (figure-A). Now check insulation as per clause. 3. Connect insulation tester between shorting terminal of AC input & earth (figure-B). Now check insulation as per clause. 4. Connect insulation tester between shorting terminal of DC output & earth (figure-C). Now check insulation as per clause. 5. Similarly now short DC input terminal and DC output terminal separately as shown in figure A, B & C for MPPT 6. Connect insulation tester between shorting terminal of DC input and earth (figure-A). Now check insulation as per clause. 7. Connect insulation tester between shorting terminal of DC output & earth (figure-B). Now check insulation as per clause. 8. Connect insulation tester between shorting terminal of DC input & DC output (figure-C). Now check insulation as per clause.
Test limits	A) FR/FC a) AC Input & Earth - Greater than 2 meg Ohm b) DC Output & Earth - Greater than 1 meg Ohm

	<p>c) AC Input & DC output - Greater than 5 meg Ohm</p> <p>B) MPPT</p> <p>a) DC Input & Earth - Greater than 2 meg Ohm</p> <p>b) DC Output & Earth - Greater than 1 meg Ohm</p> <p>c) DC Input & DC output - Greater than 5 meg Ohm</p>
Expected Results	Module should pass as per define limit in GR

DRAFT

Test No.	Test Case-23 (Voltage Proof Test)
Test Details	Clause no. 5.5.2
Test Setup	
Test Procedure	<ol style="list-style-type: none"> 1. Short AC input terminal and DC output terminal separately as shown in figure A, B & C. 2. Connect High Voltage tester between shorting terminal of AC input and DC output (figure-A). Now check insulation as per clause. 3. Connect High Voltage tester between shorting terminal of AC input & earth (figure-B). Now check insulation as per clause. 4. Connect High Voltage tester between shorting terminal of DC output & earth (figure-C). Now check insulation as per clause. 5. Similarly now short DC input terminal and DC output terminal separately as shown in figure A, B & C for MPPT 6. Connect High Voltage tester between shorting terminal of DC input and earth (figure-A). Now check insulation as per clause. 7. Connect High Voltage tester between shorting terminal of DC output & earth (figure-B). Now check insulation as per clause. 8. Connect High Voltage tester between shorting terminal of DC input & DC output (figure-C). Now check insulation as per clause.
Test limits	The Voltage Proof Test of a fully wired FR/FC & MPPT Module with EMI/RFI capacitors and MOVs/Tranzorbs removed the circuit a test voltage of 1500V/50Hz is applied for one minute.

	<ul style="list-style-type: none"> - Between earth and interconnected output terminals. - Between interconnected input and output terminals. <p>Alternatively without removing EMI/RFI capacitors, the lightning protection circuitry and Tranzorbs etc., but with EMI/RFI discharge resistors removed :</p> <ul style="list-style-type: none"> a) A 2150V DC can be applied for one minute between interconnected input and output terminals. b) 650V DC can be applied for one minute between interconnected input and output terminals and earth. <ol style="list-style-type: none"> 1. This DC voltage test is in accordance with UL 950 and IEC 950 Standards No. breakdown or abnormal temperature rise shall occur.
Expected Results	No breakdown or abnormal temperature rise occur during test.

DRAFT

Test No.	Test Case-24 (Noise)
Test Details	Clause no. 6.2
Test Setup	
Test Procedure	<ol style="list-style-type: none"> 1. Connect AC input to SMPS section & DC input to Solar CCU section. Connect DC load at the output of system. 2. Set noise meter at distance as specified in GR. 3. Turn on AC & DC input supply. Turn on DC load also. 4. Connect Laptop to monitor system performance. 5. Measure noise reading from front, back, left & right of the system at different voltage & current.
Test limits	Noise shall be measured at a distance of 1 meter from the unit & 1.25m above the floor level in the Acoustic Range. The fully equipped rack at full load shall not contribute more than 15 dB (weighted) to the ambient noise level taken as 45dBA.
Expected Results	For result and limit, please refer GR.

Test No.	Test Case-25 (Bus-Bar)
Test Details	Clause no. 8.4
Test Setup	
Test Procedure	<ol style="list-style-type: none"> 1. Connect AC input to SMPS section & DC input to Solar CCU section. Connect DC load at the output of system. 2. Connect Laptop to DSCA to change or monitor parameter or through controller display. 3. Measure mV drop between battery and exchange riser. 4. Measure mV drop between the output of the farthest FR/FC Module and Exchange riser (if applicable)
Test limits	<p>The Bus-bar shall be capable to carry current density of 2 Amps/mm.</p> <p>The Bus-bar/cable size shall also ensure that the voltage drop between the output of the farthest FR/FC module riser and also between battery and exchange riser, as per the layout drawing shall be less than 500mV</p>
Expected Results	Check system performance and limit as specified in GR.

Test No.	Test Case-26 (Meters)
Test Details	Clause no. 8.6
Test Setup	
Test Procedure	<ol style="list-style-type: none"> 1. Connect multimeter or Analyzer at AC input & DC input side to measure AC voltage. 2. Connect multimeter or analyzer/clamp meter at load path to measure DC output voltage and current. 3. Connect multimeter or analyzer at battery path shunt to measure mV for battery current measurement. 4. Check voltage, current over DSCA and compare with value showing in meter for accuracy.
Test limits	<p>The Meters & Shunts shall comply with</p> <ol style="list-style-type: none"> 1. Current: +/-1.5% of the range or better, shall be able to read up to full digit for meter range 50A & above & 1 place decimal for lower range. 2. Voltage: +/-1.5% of the range or better with a resolution of one decimal point in case of DC voltmeter and full digit in case of AC voltmeter.
Expected Results	Check measurement accuracy as specified in GR

I. SUMMARY OF TEST RESULTS

TEC Standard No. _____

TEC Guide No. _____

Equipment name & Model No. _____

<i>Clause No.</i>	<i>Compliance</i> <i>(Complied /Not Complied / Submitted/Not Submitted / Not Applicable)</i>	<i>Remarks / Test Report Annexure No.</i>

[Add as per requirement]

Date:

Place:

Signature & Name of TEC testing Officer /
* Signature of Applicant / Authorized Signatory

* Section J as given above is also to be submitted by the Applicant/ Authorised signatory as part of in-house test results along with Form-A. The Authorised signatory shall be the same as the one for Form 'A'.